

**CLEAN DEVELOPMENT MECHANISM  
PROJECT DESIGN DOCUMENT FORM (CDM-SSC-PDD)  
Version 03 - in effect as of: 22 December 2006**

**CONTENTS**

- A. General description of the small scale project activity
- B. Application of a baseline and monitoring methodology
- C. Duration of the project activity / crediting period
- D. Environmental impacts
- E. Stakeholders' comments

**Annexes**

- Annex 1: Contact information on participants in the proposed small scale project activity
- Annex 2: Information regarding public funding
- Annex 3: Baseline information
- Annex 4: Monitoring Information

**Revision history of this document**

<b>Version Number</b>	<b>Date</b>	<b>Description and reason of revision</b>
01	21 January 2003	Initial adoption
02	8 July 2005	<ul style="list-style-type: none"><li>• The Board agreed to revise the CDM SSC PDD to reflect guidance and clarifications provided by the Board since version 01 of this document.</li><li>• As a consequence, the guidelines for completing CDM SSC PDD have been revised accordingly to version 2. The latest version can be found at <a href="http://cdm.unfccc.int/Reference/Documents">http://cdm.unfccc.int/Reference/Documents</a>.</li></ul>
03	22 December 2006	<ul style="list-style-type: none"><li>• The Board agreed to revise the CDM project design document for small-scale activities (CDM-SSC-PDD), taking into account CDM-PDD and CDM-NM.</li></ul>

CDM – Executive Board

**SECTION A. General description of small-scale project activity**
**A.1 Title of the small-scale project activity:**

&gt;&gt;

**Project title:** Paekdusan Songun Youth 14 MW Hydropower Project No.2**Version number of the document:** 2.0**Date of completion:** 15/11/2011

Revision history of the document:

Version of document	Date of the document	Reason for revision
Version 1.0	25/07/2011	-
Version 2.0	15/11/2011	The document was revised according to the resolution of corrective action and clarification request of CEC.

**A.2. Description of the small-scale project activity:**

&gt;&gt;

Paekdusan Songun Youth 14 MW Hydropower Project No.2 (hereafter referred to as the Project) developed by Namgang Hydropower Construction Complex is a new reservoir type hydropower plant located on the downstream of Hwangtoam-su River, a branch of Sodu-su River at Yuphyong-gu, Paekam County, Ryanggang Province, DPR Korea.

Total installed capacity of the project will be 14 MW, consisting of two sets of 7 MW hydropower turbines and associated generators.

The purpose of the project is to utilize the hydrological resources of Hwangtoam-su River to generate non-emission electricity which will be delivered to the Eastern Power Grid (EPG), DPR Korea through Paekam transformer station.

The project will achieve greenhouse gas (GHG) emission reductions by displacing equivalent amount of electricity supplied by the EPG, which is dominated by fossil fuel-fired power plants. It is estimated that the total electricity produced by the proposed project will be 55.200 GWh/yr and the net electricity (excluding auxiliary electricity consumption and transmission loss) delivered to the EPG will be 53.990 GWh/yr<sup>1</sup>, which is equivalent to 47,689 tCO<sub>2</sub>e of the annual emission reductions.

The project is expected to be put into operation on 1 January 2014.

The project is located in Paekam County, Ryanggang Province, DPR Korea. The project clearly fits with the development priority of DPR Korea<sup>2</sup> and the regional development strategy of Ryanggang province to achieve sustainable development. After the implementation of the project, shortage of electricity supply in Paekam County and Samjiyon County will be mitigated and electricity supply to the local areas will be

<sup>1</sup> Feasibility Study Report of Paekdusan Songun Youth 14 MW Hydropower Project No.2, May 2009, Central Electric Power Design Research Institute, Ministry of Electric Industry

<sup>2</sup> Law of DPR Korea on Electric Power, 5 August 2008, Law Publishing Company

CDM – Executive Board

stabilized improving the development of the local economy.

### **Contribution of the Project to Sustainable Development**

The project will not only supply renewable energy to the grid, but also contribute to sustainable development of the local community by means of:

- Saving the fossil fuel resources in DPR Korea;
- Reducing emissions of greenhouse gases and other pollutants caused from coal-fired power plants compared with a business-as-usual scenario by displacing part of electricity from fossil fuel-fired power plants appertained to the EPG;
- Creating new jobs for local residents during the project construction and operation;
- Alleviating power shortage in the local areas, stimulating the local economy development;
- Improving living standards of local residents;
- Contributing to the protection of environment and biological resources protection in local area. The population in the project area now almost depends on bio-materials including firewood for cooking and heating, however, if the project is implemented, local people can utilize renewable energy that leads to the protection of the local forest resources and consequently contributes to the protection of biological resources;
- Accelerating use of hydropower resources for sustainable energy production in DPR Korea.

In view of above, the project strongly contributes to the sustainable development in DPR Korea.

### **A.3. Project participants:**

&gt;&gt;

<b>Name of Party involved(*) ((host) indicates a host party )</b>	<b>Private and/or public entity(ies) Project participants(*) (as applicable)</b>	<b>Kindly indicate if the Party involved wishes to be considered as project participant(Yes/No)</b>
Democratic People's Republic of Korea(host)	Namgang Hydropower Construction Complex	No
Czech Republic	Topič Energo s.r.o.	No

Detailed contact information is available in Annex 1.

### **A.4. Technical description of the small-scale project activity:**

#### **A.4.1. Location of the small-scale project activity:**

&gt;&gt;

##### **A.4.1.1. Host Party (ies):**

&gt;&gt;

Democratic People's Republic of Korea

##### **A.4.1.2. Region/State/Province etc.:**

&gt;&gt;

---

CDM – Executive Board

Ryanggang Province

<b>A.4.1.3. City/Town/Community etc:</b>
--

>>

Yuphyong-gu, Paekam County

<b>A.4.1.4. Details of physical location, including information allowing the unique identification of this <u>small-scale project activity</u> :</b>
--

>>

The project is located at the midstream of Sodu-su River, Yuphyong-gu, Paekam County, Ryanggang Province, DPR Korea, approximately 23 km away from Paekam County. Hwangtoam-su River is a branch of Sodu-su River at the midstream.

The exact geographical location of project is E 128°50' 15" and N 41°43'18" respectively. More details about the proposed project can be seen in Figure 1:

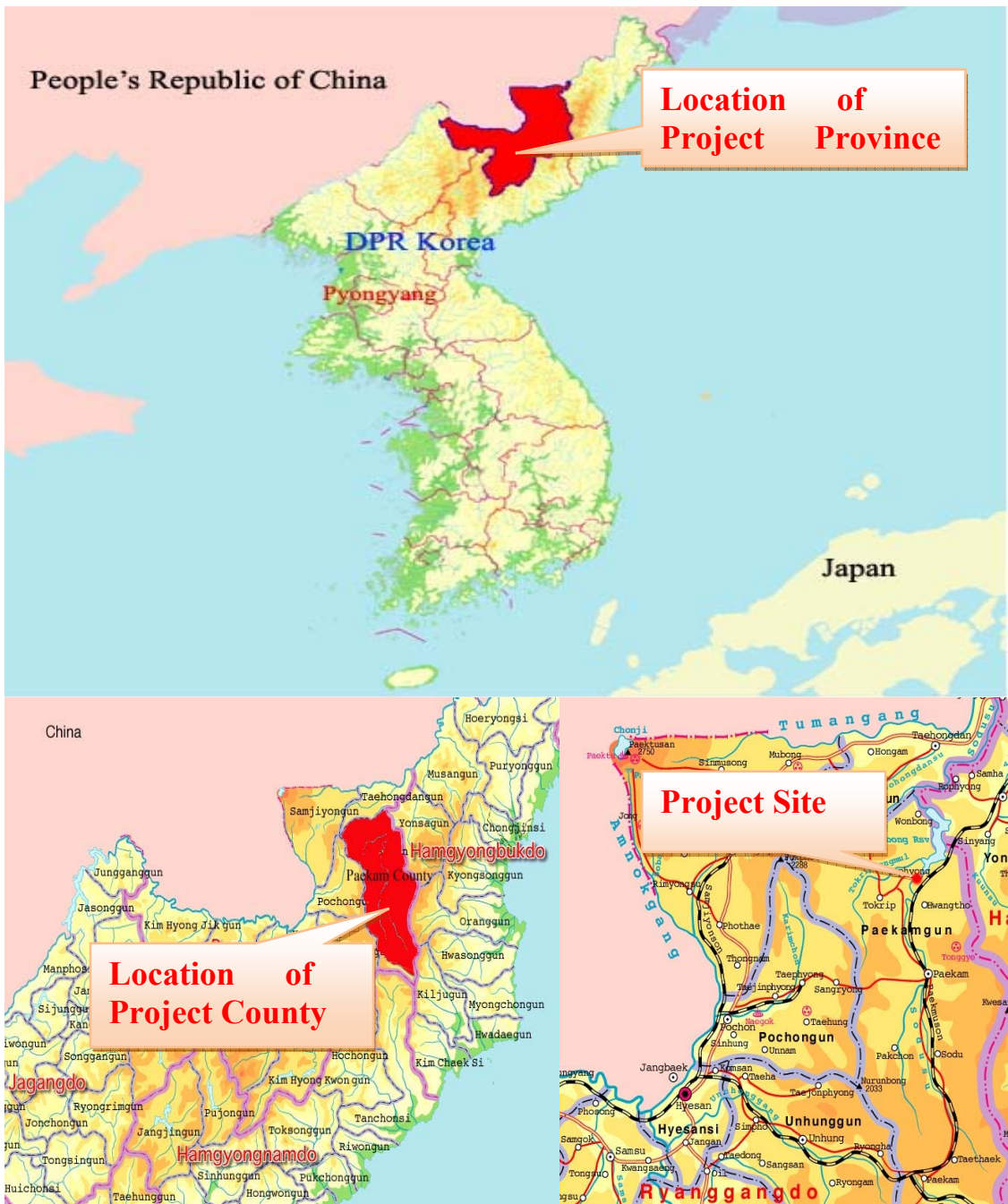

Figure 1. Location of the project

**A.4.2. Type and category (ies) and technology/measure of the small-scale project activity:**

>>

**1. Type and category (ies) of the small-scale project activity**

According to Appendix B<sup>3</sup> to the *Simplified Modalities and Procedures for Small-scale CDM Project*

<sup>3</sup> UNFCCC web site: <http://cdm.unfccc.int/Projects/pac/ssclistmeth.pdf>

CDM – Executive Board

*Activities*, the type and category of the project are defined as follows:

Type I: Renewable energy projects

Category I.D: Renewable Energy Generation for a Grid

Sub-category: Hydro

Reference: AMS-I.D, version 17, EB 61

The project falls into the Category I.D. since the project aims at generating electricity from renewable hydro energy and supplying to the grid and the installed capacity of the project is 14 MW which is less than the specified capacity of 15 MW to SSC-CDM.

The generated electricity by the project will be connected to the EPG through Paekam transformer station.

## 2. Application of environmentally sound and safe technology

The project activity does not involve any greenhouse gas emissions or burning of any fossil fuels during the process of power generation. The technology employed for the project activity is the current best practice in small hydro power sector in DPR Korea. And also, the project construction will not permit a negative damage to the ecosystem. Hence, the technology applied for the project activity is environmentally safe and sound.

## 3. Technologies applied on the small-scale project activity

The project is a newly-built hydropower plant with a total installed capacity of 14 MW (7 MW × 2) which is located at Yuphyong-gu, Paekam County, Ryanggang Province and a design operation life is about 20 years. The project is consisted of a diversion weir, a river diversion tunnel, surge tank, high pressure pipelines, a powerhouse and a transformer station. The normal water level of the reservoir is 965.5 m and the total volume of the reservoir is 870,000 m<sup>3</sup>, the water surface area of the reservoir at full level is 0.19 km<sup>2</sup>, and thus the power density is 73.68 W/m<sup>2</sup>. Through the diversion weir and tunnel, the average water head of 45.28 m is formed taking advantage of the natural height drop. The hydraulic pressure of the water is increased through the high pressure pipelines, and then the water flows into the powerhouse and drives the generator to generate electricity. The length and height of the dam is 127 m and 27 m. The total length and diameter of the tunnel is 2.19 km and 4.2 m, respectively. The length and diameter of the high pressure pipelines is 75.69 m and 2.5 m. Two sets of facilities with 7,000 kW are installed by the project. The 6.6 kV voltage of electricity generated by the generator is boosted to 66 kV in the step-up station of the project.

The electricity produced by the project is supplied to Paekam transformer station connected to the EPG with 66 kV transmission line. The expected annual net electricity supply by the project to the grid is 53.990 GWh.

According to Feasibility Study Report, the key technical parameters of the hydro turbines and generators of the project are listed in Table 1.

Table1. Key technical parameters of hydro turbines and generators

Turbine		
Item	Unit	Data
Type	-	210-vertical 180
Installed number	unit	2

CDM – Executive Board

Diameter	m	1.8
Rated rotate speed	rpm	257
Rated water head	m	40
Maximum flow quantity	m <sup>3</sup> /s	20.4
Rated output	MW	7.4
Efficiency	%	92
Manufacturer	-	Taeon Heavy Machinery Complex
<b>Generator</b>		
Type		Dongsuse 7,000-6.6/257
Installed Capacity per set	MW	7
Installed number	set	2
Frequency	Hz	60
Voltage	kV	6.6
Rated efficiency	%	95
Rated rotate speed	rpm	257
Power coefficient	cosφ	0.8
Manufacturer	-	Taeon Heavy Machinery Complex

#### 4. Technology transfer

All technologies utilized in the project are domestic and no technology will be transferred to DPR Korea from abroad through the project.

#### **A.4.3 Estimated amount of emission reductions over the chosen crediting period:**

&gt;&gt;

A 10 year fixed crediting period is chosen for the proposed project activity. The crediting period will start at 1 January 2014. During the period, the total estimated emission reductions are 476,894 tCO<sub>2</sub>e. Please refer to section B.6.3 for further details on the quantification of GHG emission reductions associated with the project. The annual and total emission reductions are explained in the following table 2:

Table 2. Estimation of emission reductions during crediting period

Years	Annual estimation of emission reductions in (tCO <sub>2</sub> e)
01/01/2014-31/12/2014	47,689
01/01/2015-31/12/2015	47,689
01/01/2016-31/12/2016	47,689
01/01/2017-31/12/2017	47,689
01/01/2018-31/12/2018	47,689
01/01/2019-31/12/2019	47,689
01/01/2020-31/12/2020	47,689
01/01/2021-31/12/2021	47,689
01/01/2022-31/12/2022	47,689



CDM – Executive Board

01/01/2023-31/12/2023	47,689
Total estimated reductions (tonnes of CO <sub>2</sub> e)	<b>476,894</b>
Total number of crediting years	<b>10</b>
Annual average over the crediting period of estimated reductions (tonnes of CO <sub>2</sub> e)	<b>47,689</b>

**A.4.4. Public funding of the small-scale project activity:**

&gt;&gt;

No public funding from parties included in Annex I of UNFCCC is available to the project activity.

**A.4.5. Confirmation that the small-scale project activity is not a debundled component of a large scale project activity:**

&gt;&gt;

According to the Appendix C of the *Simplified Modalities and Procedures for small-scale CDM project activities*, a small-scale project is considered a debundled component of a larger project activity if there is no a registered small-scale CDM project activity or an application to register another small-scale CDM activity:

- With the same project participants;
- In the same project category and technology/measure;
- Registered within the previous 2 years; and
- Whose project boundary is within 1 km of the project boundary of the proposed small scale activity at the closest point.

The project participants confirm that none of the conditions mentioned above is applicable to this project activity. The project proponents further confirm that they have not registered any small scale CDM activity or apply to register another small scale CDM project activity within the same project boundary, in the same project category and technology.

Accordingly, the project is not a debundled component of a larger project activity.

**SECTION B. Application of a baseline and monitoring methodology**
**B.1. Title and reference of the approved baseline and monitoring methodology applied to the small-scale project activity:**

&gt;&gt;

The methodology applied for the proposed project is the approved methodology for small-scale CDM project- “AMS-I.D, Grid connected renewable electricity generation” (Version 17, EB 61) and “Tool to calculate the emission factor for an electricity system (Version 02.2.1, EB 63)”. For more information regarding the methodology, please refer to the link:

<http://cdm.unfccc.int/methodologies/SSCmethodologies/approved.html>.

<http://cdm.unfccc.int/methodologies/PAmethodologies/approved.html>.

**B.2 Justification of the choice of the project category:**

&gt;&gt;

The project activity meets all the applicability conditions of the AMS-I.D (version 17) as described

CDM – Executive Board

below:

### Applicability of AMS-I.D

The applicability conditions for simplified baseline methodology category AMS-I.D are:

- The project should comprise renewable energy generation units, such as photovoltaic, hydro, tidal/wave, wind, geothermal and renewable biomass that supplying electricity to a national or a regional grid or supplying electricity to an identified consumer facility via national/regional grid through a contractual arrangement such as wheeling.
- The project should be such that (a) install a new power plant at a site where there was no renewable energy power plant operating prior to the implementation of the project activity (Greenfield plant); (b) involve a capacity addition; (c) involve a retrofit of (an) existing plant(s); or (d) involve a replacement of (an) existing plant(s).
- Hydro power plants with reservoirs that satisfy at least one of the following conditions are eligible to apply this methodology
  - The project activity is implemented in an existing reservoir with no change in the volume of reservoir;
  - The project activity is implemented in an existing reservoir, where the volume of reservoir is increased and the power density of the project activity, as per definitions given in the project emissions section, is greater than  $4 \text{ W/m}^2$ ;
  - The project activity results in new reservoirs and the power density of the power plant, as per definitions given in the project emissions section, is greater than  $4 \text{ W/m}^2$ .
- If the new unit has both renewable and non-renewable components (e.g., a wind/diesel unit), the eligibility limit of 15 MW for a small-scale CDM project activity applies only to the renewable component. If the new unit co-fires fossil fuel, the capacity of the entire unit shall not exceed the limit of 15 MW.
- Combined heat and power (co-generation) systems are not eligible under this category.

### For the proposed project:

- The proposed project activity is the **hydropower** project, which supplies electricity to EPG.
- This hydropower plant will be newly built at a site where there was no renewable energy power plant operating prior to the implementation of the project activity.
- The project activity results in a new reservoir and the power density of the power plant will be  $73.68 \text{ W/m}^2$ , which is greater than  $4 \text{ W/m}^2$ .
- The installed capacity of the project is 14 MW, which is smaller than 15 MW.
- The proposed project is not combined heat and power (co-generation) system.

Hence, the project qualifies for the application of methodology AMS-I.D – Grid connected renewable electricity generation.

### Demonstration for being within the limits of SSC throughout the crediting period

The FSR demonstrated that the project activity will remain under the limits of SSC throughout the crediting period. The design flow quantity has been found out to be  $20.4 \text{ m}^3/\text{s}$  and the head available has been estimated as 40 m. Based on the head available and design flow quantity, the maximum capacity of the power project has been determined as 14 MW. Keeping the above considerations in view, and also the maximum electricity generating capacity limited by the design of the plant and machinery and the license issued by the state authorities, there is no possibility of exceeding the limits of small-scale CDM project

CDM – Executive Board

activity throughout the crediting period.

**B.3. Description of the project boundary:**

>>

Based on the methodology AMS-I.D, the spatial extent of the project boundary includes the project power plant and all power plants connected physically to the EPG of DPR Korea that is the electricity system where the CDM project power plant is connected to. According to the definition of the DNA<sup>4</sup>, the EPG covers four provinces (North Hamgyong, South Hamgyong, Ryanggang, Kangwon).

Table3. Emissions sources included in or excluded from the project boundary

	Source	Gas	Included?	Justification/Explanation
<b>Baseline</b>	Electricity generation by the EPG	CO <sub>2</sub>	Yes	Main emission source
		CH <sub>4</sub>	No	Minor emission source
		N <sub>2</sub> O	No	Minor emission source
<b>Project Activity</b>	Proposed project	CO <sub>2</sub>	No	Minor emission source
		CH <sub>4</sub>	No	Main emission source. The project is grid-connected electricity generation from a hydropower plant with power density of 73.68 W/m <sup>2</sup> which is greater than 10 W/m <sup>2</sup> , thus there is no need to take into account CH <sub>4</sub> emissions
		N <sub>2</sub> O	No	Minor emission source

**B.4. Description of baseline and its development:**

>>

The baseline of the project is determined based on the methodology AMS-I.D

According to methodology AMS-I.D, the baseline scenario is that the electricity delivered to the grid by the project activity would have otherwise been generated by the operation of grid-connected power plants and by the addition of new generation sources into the grid.

Plausible and credible alternatives available to the project that provide outputs or services comparable with the proposed CDM project activity include:

- (1) The proposed hydropower plant development not undertaken as a CDM project activity;
- (2) Construction of a fossil fuel power plant with the same amount of annual electricity generation;
- (3) Construction of a power plant using other renewable energy sources with the same annual electricity generation;
- (4) Provision of equivalent amount of annual power output by the EPG which the proposed project is connected to.

Of the four scenarios,

**Scenario1.** The proposed hydropower plant development not undertaken as a CDM project activity.

In viewpoint of the proposed project's investment benefit, the investment risk is

<sup>4</sup> DPR Korea's Grid definition, 15 July 2011, DNA

comparatively high. If the project is not implemented as a CDM project, the IRR of the Project will be less than the benchmark (5%). Therefore, alternative (1) is not feasible.

**Scenario2.** Construction of a fossil fuel power plant with the same amount of annual electricity generation.

According to the current laws and regulations in DPR Korea, the construction of coal-fired power plants is consistent with the energy development strategy in DPR Korea. In case of the project, the construction of fossil fuel power plant is impossible. At first there are no resources of crude oil and natural gas in DPR Korea<sup>5</sup>. The project site is very far from the main coal mines in DPR Korea. The project site is located on the highland and thus the cost for transportation of coal needed to operate coal-fired power plant is extremely expensive. Consequently, the construction of coal-fired power plant is uneconomic and alternative (2) is not feasible.

**Scenario3.** Construction of a power plant using other renewable energy sources with the same annual electricity generation.

Apart from hydropower resource, wind power, solar PV, geothermal resource and biomass resource are renewable zero-emitting resources. Although certain amount of wind power exists in the project site, it is impossible to develop wind resource due to the technology immaturity in DPR Korea. This is likewise in solar PV. The solar PV is far from being mature in DPR Korea. It is also impossible to generate electricity from biomass and geothermal resources for the reason that biomass resource is not sufficient and no geothermal resource has been exploited in the project site.

In a word, the electricity generation by renewable resources needs high cost and the technology is not mature in DPR Korea. For the above reasons, Alternative (3) is therefore not feasible nor is the baseline scenario.

**Scenario4.** Provision of equivalent amount of annual power output by the EPG which the proposed project is connected to.

Alternative (4) is economically viable, and in compliance with current national legal and regulatory requirements in DPR Korea.

### Conclusion:

From above analysis, it is evident that the scenario 4 is the only plausible and credible alternative to the project. The provision of equivalent amount of electricity by the EPG is the only realistic baseline scenario to the project.

The baseline emissions are the product of electrical energy baseline  $EG_{BL,y}$  expressed in MWh of electricity produced by the renewable generating unit multiplied by the grid emission factor.

The emission factor can be calculated in a transparent and conservative manner as follows:(a) A combined margin (CM), consisting of the combination of operating margin (OM) and build margin (BM) according to the procedures prescribed in the "Tool to calculate the Emission Factor for an electricity system"; OR (b) The weighted average emissions (in t CO<sub>2</sub>/MWh) of the current generation mix. The data of the year in which project generation occurs must be used.

The boundary of the proposed project is EPG, so the boundary when calculating OM and BM are set with

---

<sup>5</sup> DPRK's First National Communication under the Framework Convention on Climate Change, 19, April 2000, Ministry of Land and Environment Protection.

CDM – Executive Board

EPG.

The basic parameters used for calculating baseline emissions are provided in Table 4:

Table 4. Basic parameters used for calculating baseline emissions

Parameter	Value	Data Source
The operating margin emission factor ( $EF_{grid,OM,y}$ ) of the EPG (t CO <sub>2</sub> e/MWh)	0.883,3	Calculated according to the Official Data of Central Bureau of Statistics and 2006 IPCC guideline
The build margin emission factor ( $EF_{grid,BM,y}$ ) of the EPG (t CO <sub>2</sub> e/MWh)	0	-
Net electricity delivered to the grid ( $EG_{facility,y}$ ) (MWh)	53,990	Feasible Study Report

**B.5. Description of how the anthropogenic emissions of GHG by sources are reduced below those that would have occurred in the absence of the registered small-scale CDM project activity:**

The project is a small scale project activity. As such, the provisions of Attachment A to Appendix B of the *simplified modalities and procedures for small-scale CDM project activities* will apply to the project. The ‘*indicative simplified baseline and monitoring methodologies for selected small-scale CDM project activity categories*’ require the project proponents to show that the project activity would not have occurred anyway due to *at least one* of the following barriers:

- (a) Investment barrier
- (b) Technological barrier
- (c) Barrier due to prevailing practices / common practice
- (d) Other barriers

The barriers specified in Attachment A to Appendix B are:

**a) Investment barrier:** A financially more viable alternative to the project activity would have led to higher emissions.

**b) Technological barrier:** A less technologically advanced alternative to the project activity involves lower risks due to the performance uncertainty or low market share of the new technology adopted for the project activity and so would have led to higher emissions.

**c) Barrier due to prevailing practice:** Prevailing practice or existing regulatory or policy requirements would have led to the implementation of a technology with higher emissions.

**d) Other barriers:** Without the project activity, for another specific reason identified by the project participant, such as institutional barriers or limited information, managerial resources, organizational capacity, financial resources, or capacity to absorb new technologies, emissions would have been higher.

The main barrier existing in the project is an investment barrier.

**Investment barrier**

Investment barrier is the main barrier the project may face. Without the revenue from CDM, the Project would never be implemented.

The purpose of this part is to determine whether the project is economically attractive or not through appropriate analysis method.

**(1) Determination of appropriate analysis method**

The “*Tool for the Demonstration and Assessment of Additionality (Version 06.0)*” recommends three analysis methods which are:

- Option I: Simple cost analysis;
- Option II: Investment comparison analysis;
- Option III: Benchmark analysis;

Since the project will earn revenues not only from the CERs sales but also from electricity sales, the simple cost analysis method is not appropriate. Investment comparison analysis method is only applicable to projects whose alternatives are similar investment projects. However, the most credible alternative of the Project is the provision of equivalent amount of annual electricity output by the EPG, DPR Korea. This alternative is not an investment project, so the investment comparison analysis can't be applied. The benchmark IRR of total investment is available, so the benchmark analysis is chosen.

Conclusion: Option III is only appropriate for the analysis of the additionality of the project activity.

**(2) Selection and Validation of Appropriate Benchmarks**

EB 62 Report Annex 5, “Guidelines on the Assessment of Investment Analysis” (Version 05), section 12 requires,

“In cases where a benchmark approach is used the applied benchmark shall be appropriate to the type of IRR calculated. Local commercial lending rates or weighted average costs of capital (WACC) are appropriate benchmarks for a project IRR. Required/expected returns on equity are appropriate benchmarks for equity IRR. Benchmarks supplied by relevant national authorities are also appropriate if the DOE can validate that they are applicable to the project activity and the type of IRR calculation presented.” Also section 13 requires: “In the cases of projects which could be developed by an entity other than the project participant the benchmark should be based on parameters that are standard in the market.”

According to the “Guideline for Determination of Main Parameters of Hydropower Plant” issued by the Ministry of State Construction Control in 2006, the benchmark of the financial internal rate of return for a hydropower project with the capacity of more than 1 MW is 5%<sup>6</sup>. The calculation and comparison of financial indicators are carried out based on this benchmark.

Although the applied IRR benchmark was issued in 2006, which is still the most specific benchmark for this type of project. It was confirmed again in 2010 by the Ministry of State Construction Control<sup>7</sup> that this benchmark is still in effect in 2010. Therefore the 5% benchmark is representing the common practice of DPR Korea for investment decision processes for hydro projects.

---

<sup>6</sup> Guideline for Determination of Main Parameters of Hydropower Plant, November 2006, Ministry of State Construction Control

<sup>7</sup> Notice of State Construction Control, 2010

CDM – Executive Board

**(3) Calculation and comparison**

Based on the Feasibility Study Report of the Project, the basic parameters for calculation of financial indicators are shown in Table 5

Table 5. Basic parameters for calculation of financial indicators of the project

Parameters	Value	Source
Installed capacity(MW)	14	FSR
Annual operating time (h)	3,943	FSR
Construction period (yr)	3	FSR
Plant load factor (%)	45	FSR
Net electricity supplied to EPG (MWh/yr)	53,990	FSR
Total investment (10,000 KPW)	127,233	FSR
Annual loan rate (%)	3.6	FSR
O & M cost (10,000 KPW/yr)	1,554	FSR
Electricity Price (KPW/kWh)	1.98	Guideline for determination of main parameters of hydro power plants
Depreciation rate (%)	Construction: 2	Guideline for determination of main parameters of hydro power plants
	Equipment: 5	
Government payment (%)	30	Guideline for determination of main parameters of hydro power plants
Project lifetime (yr)	20	FSR

When calculating the IRR without the sale revenue of CER as per the data given in table 5, the IRR is only 3.69% which is lower than the benchmark 5%. Therefore, the project is unattractive and requires the additionality.

With the sale revenue of CER, the IRR of the project is 7.86% and exceeds the benchmark 5%. In this case, the project is attractive, which means, as a result, that the revenue of CDM is able to help the project to overcome the investment barrier.

Table 6. IRR of the Project

Financial indicators	Without income from CDM	Benchmark	With income from CDM
IRR	3.69%	5%	7.86%

**Sensitivity analysis**

This step is to confirm that whether the conclusion regarding the financial attractiveness is robust to reasonable variations in the critical assumptions.

EB 62 Report Annex 5, “Guidelines on the Assessment of Investment Analysis” (Version 05), section 20 requires:

“Only variables, including the initial investment cost, that constitute more than 20% of either total project costs or total project revenues should be subjected to reasonable variation (all parameters varied need not necessarily be subjected to both negative and positive variations of the same magnitude), and the results of this variation should be presented in the PDD and be reproducible in the associated spreadsheets.”

The following four parameters are selected as the critical sensitivity indicators to check the financial attractiveness of the Project:

1. Fixed assets investment

## CDM – Executive Board

2. Annual O&M cost
3. Feed-in electricity
4. Electricity price

In the FSR, sensitivity analysis was conducted to check under variation of  $\pm 10\%$ , so variations of  $\pm 10\%$  have been considered for these parameters. Table 7 summarizes the results of the sensitivity analysis, while Figure 2 provides a graphic depiction.

Table 7. Result of sensitivity analysis

Item	-10%	-5%	0	5%	+10%
Fixed assets investment	4.30%	3.98%	3.69%	3.44%	3.21%
Annual O&M cost	3.79%	3.74%	3.69%	3.65%	3.60%
Feed-in electricity	3.04%	3.37%	3.69%	4.02%	4.34%
Electricity price	3.04%	3.37%	3.69%	4.02%	4.34%

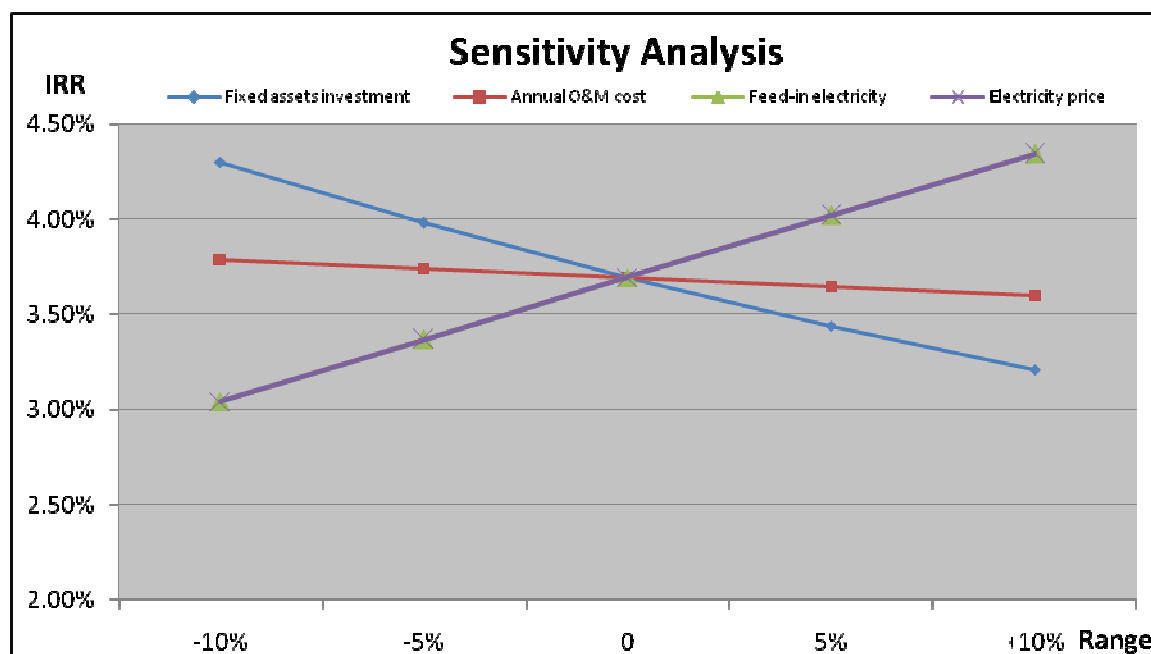

Figure 2. IRR Sensitivity Analysis

Figure 2 show that none of variations can increase the IRR of the proposed project higher than the benchmark of 5%.

When a decrease in investment has reached 14.8%, the project IRR can reach the benchmark. However, the investment of the project is larger than the value estimated in the FSR. The main investment is consisted of construction cost, equipment cost and transportation cost. The tunnel of the proposed project is 2.19 km in length and the condition for construction of this tunnel is unfavorable, so it is impossible to reduce the investment. The dam is rock-filled dam, thus technical requirement is very high and investment is also high. The project site is located on the highland and very far from the site of the main construction materials, therefore the cost for transportation is extremely expensive. The project is still



under construction, so the actual investment will be higher. Therefore, it is impossible to improve the economic attraction of the project due to the increase in investment.

As seen in the table 7, the sensitivity of the annual O & M cost is very low. The annual O & M cost is calculated according to the data from approved FSR. Thus the actual annual O & M cost will be increased due to the increased salary. In conclusion, considering the increase of employees' payroll and other fixed indexes of annual O & M cost, the annual O & M cost used is conservative and credible. Therefore, it is also impossible to adjust annual O & M cost to raise the IRR significantly.

When an increase in electricity supplied to the grid reaches 20.4%, the project IRR can reach the benchmark. The electricity output described in the FSR is the estimated value based on the survey result of the water resource in the relevant observation station for 30 years. The hydrometeorology data in the project site was sourced from the Central Bureau of Statistics. Therefore, the electricity output estimated in the FSR could not be changed largely.

When an increase in electricity price has reached 20.4%, the project IRR can reach the benchmark. But, according to the decision of the State Price Assessment Committee in August, 2001, the electricity price in DPR Korea is 1.98 KPW/kWh. The electricity price will not be changed unless the State Price Assessment Committee would change the electricity price. Considering the current trend in electricity price, the project IRR can not reach the benchmark due to the unchangeable trend in electricity price.

In the other hand, the project IRR will increase greatly when the project receives the CERs revenue. If the CERs price is taken as 10 USD/tCO<sub>2</sub>e into account, the project IRR reaches 7.86% which is greater than the benchmark, thus the repayment of capital and interest will be increased and the financial situation will be improved.

As mentioned above, IRR of the project is difficult to reach the benchmark 5% without CERs revenue, which supports the conclusion, that the proposed project is unlikely to be financially attractive. Therefore, the proposed project is additional.

### **CDM consideration**

The project owner received the FSR made by Central Electric Power Design Institute, Ministry of Electric Industry in May 2009. According to the FSR, the IRR of the proposed project is 3.69% which is less than 5% of benchmark. They found the proposed project was financially unattractive. So the project owner could not invest to the project.

Meanwhile, the project owner tried to find out a solution to make the project financially attractive. They received the "Recommendation letter of DNA"<sup>8</sup> from Middle-Small size Power Bureau, Ryanggang Province on 3 January 2010. The notice from the DNA mentioned that the implementation of the project with CDM could increase the project IRR and thus make the project financially viable.

Subsequently, the project owner started to collect the information about CDM, at the same time they began to seek for consultant agency and they decided not to carry out the project without CDM support. Namgang Hydropower Construction Complex discussed about CDM project development with General Bureau for Cooperation with International Organizations (GBCIO) and State Academy of Sciences (SAoS). Some specialists of the GBCIO and SAoS visited and surveyed the project site for three days and acquired the data and documentation for PDD development. The specialists also visited the Middle-Small size Power Bureau of Ryanggang Province, the People's Committee of Paekam County, the Power Distribution Station in Paekam and Department of Land and Environment Protection in Paekam, and they confirmed the data for project development. According to the survey study, the specialists of SAoS

---

<sup>8</sup> Recommendation letter of DNA, February 2009, National Coordination Committee for Environment

## CDM – Executive Board

demonstrated the validity of the project as CDM project. The project owner held a board meeting to decide the development of the project as a CDM project on 19 April 2010<sup>9</sup>.

On 23 July 2010<sup>10</sup>, the project owner made a contract with GBCIO and SAoS to help them applying CDM to the proposed project.

The project owner made a contract with Paekam bank for the loan on 6 September 2010<sup>11</sup> and with the Paekdusan Songun Youth Hydropower Plant Company for construction on 7 October 2010<sup>12</sup> respectively.

The construction of hydropower plant was commenced on 16 November 2010 and then the project owner applied the project as a CDM project to the DNA on 25 January 2011<sup>13</sup>.

The Equipment Purchase Contract between Project owner and Taeon Heavy Machinery Complex was signed on 27 February 2011<sup>14</sup>. The proposed project was approved by DNA on 22 August 2011<sup>15</sup>.

Please find a detailed timeline of the project implementation in the following table.

Table 8. The timetable of the project implementation

Date	Event
20/05/2009	Approval of Feasibility Study Report
13/08/2009	Environmental Impact Assessment(EIA) Report
24/10/2009	Approval of EIA report
03/11/2009	Certificate of Forest Land Use
19/04/2010	Board meeting for CDM consideration
07/06/2010	Construction Approval
23/07/2010	PDD Development Contract
06/09/2010	Loan contract
07/10/2010	Construction contract
16/11/2010	Starting of the construction
04/01/2011	Submission of prior consideration form to EB
25/01/2011	Application of project to the DNA
27/02/2011	Equipment Purchase Contract
04/06/2011	Power Purchase Agreement
22/08/2011	Letter of Approval

<b>B.6. Emission reduction:</b>
---------------------------------

<sup>9</sup> Minutes for Application of CDM, No.37, 19 April 2010, Namgang Hydropower Construction Complex

<sup>10</sup> PDD Development Contract, 23 July 2010, GBCIO and SAoS

<sup>11</sup> Loan contract between Namgang Hydropower Construction Complex and Paekam bank, 6 September 2010

<sup>12</sup> Construction contract between Namgang Hydropower Construction Complex and Paekdusan Songun Youth Hydropower Plant Company, 7 October 2010

<sup>13</sup> Letter for Project Application, 25 January 2011, DNA

<sup>14</sup> Equipment Purchase Contract, 27 February 2011, Taeon Heavy Machinery Complex

<sup>15</sup> Letter of Approval, 22 August 2011, National Coordinating Committee for Environment

<b>B.6.1. Explanation of methodological choices:</b>
--

&gt;&gt;

In order to calculate the baseline, project and leakage emissions and hence emission reductions, methodology AMS-I.D (Version 17, EB 61) is used in conjunction with the “Tool to calculate the emission factor for an electricity system (Version 02.2.1, EB 63)”. Below is a description of how the three types of emission (baseline, project and leakage) are calculated, along with the key assumptions and rationale for methodological choices.

**Baseline Emission**

The baseline emissions are the product of electrical energy baseline  $EG_{BL,y}$  expressed in MWh of electricity produced by the renewable generating units multiplied by the grid emission factor.

$$BE_y = EG_{BL,y} * EF_{CO_2,grid,y} \quad (1)$$

Where:

$BE_y$  Baseline Emissions in year y (t CO<sub>2</sub>)

$EG_{BL,y}$  Quantity of net electricity supplied to the grid as a result of the implementation of the CDM project activity in year y (MWh)

$EF_{CO_2,grid,y}$  CO<sub>2</sub> emission factor of the grid in year y (t CO<sub>2</sub>/MWh)

The emission factor can be calculated in a transparent and conservative manner as follows:

- (a) A combined margin (CM), consisting of the combination of operating margin (OM) and build margin (BM) according to the procedures prescribed in the “Tool to calculate the Emission Factor for an electricity system”;

OR

- (b) The weighted average emissions (in t CO<sub>2</sub>/MWh) of the current generation mix.  
The data of the year in which project generation occurs must be used.

The project proponent used Option (a) i.e. combined margin emission factor and desired to keep the emission factor constant throughout the crediting period for the sake of adopting more simple approach for calculation of emission reductions.

According to “Tool to calculate the emission factor for an electricity system (Version 02.2.1)”, Project participants shall apply the following six steps to calculate the emission factor.

STEP 1. Identify the relevant electricity systems;

STEP 2. Choose whether to include off-grid power plants in the project electricity system (optional);

STEP 3. Select a method to determine the operating margin (OM);

STEP 4. Calculate the operating margin emission factor according to the selected method;

STEP 5. Calculate the build margin (BM) emission factor;

STEP 6. Calculate the combined margin (CM) emissions factor.

**Step 1: Identify the relevant electricity systems**

For determining the electricity emission factors, a **project electricity system** is defined by the spatial extent of the power plants that are physically connected through transmission and distribution lines to the project activity( e.g. the renewable power plant location or the consumers where electricity is being saved)

## CDM – Executive Board

and that can be dispatched without significant transmission constraints.

Similarly, a **connected electricity system**, e.g. national or international, is defined as an electricity system that is connected by transmission lines to the project electricity system. Power plants within the connected electricity system can be dispatched without significant transmission constraints but transmission to the project electricity system has significant transmission constraint. If a connected electricity system is located partially or totally in Annex-I countries, then the emission factor of that connected electricity system should be considered zero.

If the DNA of the host country has published a delineation of the project electricity system and connected electricity systems, these delineations should be used. If this information is not available, project participants should define the project electricity system and any connected electricity system, and justify and document their assumptions in the CDM-PDD. The following criteria can be used to determine the existence of significant transmission constraints.

- In case of electricity systems with spot markets for electricity: there are differences in electricity prices (without transmission and distribution costs) of more than 5 percent between the systems during 60 percent or more of the hours of the year;
- The transmission line is operated at 90% or more of its rated capacity during 90% percent or more of the hours of the year.

Where the application of these criteria does not result in a clear grid boundary, use a regional grid definition in the case of large countries with layered dispatch systems (e.g. provincial/regional/national). A provincial grid definition may indeed in many cases be too narrow given significant electricity trade among provinces that might be affected, directly or indirectly, by a CDM project activity. In other countries, the national (or other largest) grid definition should be used by default. Document the geographical extent of the project electricity system transparently and identify all grid power plants/units connected to the system.

For the purpose of determining the build margin emission factor, the spatial extent is limited to the project electricity system, except where recent or likely future additions to transmission capacity enable significant increases in imported electricity. In such cases, the transmission capacity may be considered a build margin source.

For the purpose of determining the operating margin emission factor, use one of the following options to determine the CO<sub>2</sub> emission factor(s) for net electricity imports from a connected electricity system:

0 tCO<sub>2</sub>/MWh; or

- (a) The weighted average operating margin (OM) emission rate of the exporting grid, determined as described in step 4 (d) below; or
- (b) The simple operating margin emission rate of the exporting grid, determined as described in Step 4 (a), if the conditions for this method, as described in Step 3 below, apply to the exporting grid; or
- (c) The simple adjusted operating margin emission rate of the exporting grid, determined as described in Step 4 (b) below.

The project is located in Ryanggang Province, DPR Korea. According to a delineation of the project electricity system published by the DNA, the project electricity system is the EPG which include the four provinces, i.e., North Hamgyong Province, South Hamgyong Province, Ryanggang Province, Kangwon Province. EPG's geographic and system boundaries can be clearly identified. There is no electricity transfer from other grid to the EPG. Therefore, no electricity import needs to be considered when

calculating operating margin emission factor.

The electricity generated by the proposed project will be supplied to the EPG through Paekam transformer station.

**Step 2: Choose whether to include off-grid power plants in the project electricity system (optional)**

Project participants may choose between the following two options to calculate the operating margin and build margin emission factor:

**Option I:** Only grid power plants are included in the calculation.

**Option II:** Both grid power plants and off-grid power plants are included in the calculation.

The proposed project is a grid connected power plant, so the Option I is selected.

**Step 3: Select a method to determine the operating margin (OM)**

“Tool to calculate the emission factor for an electricity system” (Version 02.2.1, EB 63) offers four options for the calculation of the OM emission factor ( $EF_{grid,OM,y}$ ):

- (a) Simple OM; or
- (b) Simple adjusted OM; or
- (c) Dispatch data analysis OM; or
- (d) Average OM.

Among the above methodologies, the methodology “Dispatch Data Analysis” should be the first methodological choice. However, the method is not applicable for OM emission factor calculation, because dispatch data, let alone detailed dispatch data, are not available to the public or to the project participants. For the same reason, the simple adjusted OM methodology cannot be used.

The simple OM method (option a) can only be used if low-cost/must-run resources constitute less than 50% of total grid generation in: 1) average of the five most recent years, or 2) based on long-term averages for hydroelectricity production.

This project activity is located in a country with less than 10 registered projects at the starting date of validation and the data requirements for the application of step 5 in guidance cannot be met. According to “Tool to calculate the emission factor for an electricity system” (Version 02.2.1, EB 63), Average OM method is used.

For the simple OM, the simple adjusted OM and the average OM, the emissions factor can be calculated using either of the two following data vintages:

- Ex ante option: If the ex ante option is chosen, the emission factor is determined once at the validation stage, thus no monitoring and recalculation of the emissions factor during the crediting period is required. For grid power plants, use a 3-year generation-weighted average, based on the most recent data available at the time of submission of the CDM-PDD to the DOE for validation. For off-grid power plants, use a single calendar year within the 5 most recent calendar years prior to the time of submission of the CDM-PDD for validation.
- Ex post option: If the ex post option is chosen, the emission factor is determined for the year in which the project activity displaces grid electricity, requiring the emissions factor to be updated annually during monitoring. If the data required to calculate the emission factor for year y is usually only available later than six months after the end of year y, alternatively the emission factor of the previous year y-1 may be used. If the data is usually only available 18 months after the end of year y,

## CDM – Executive Board

the emission factor of the year proceeding the previous year  $y-2$  may be used. The same data vintage ( $y$ ,  $y-1$  or  $y-2$ ) should be used throughout all crediting periods.

For the proposed project, the ex-ante option is adopted with using the data vintage as a 3-year generation-weighted average based on the most recent data for calculation of the average OM emission factor ( $EF_{grid,OM,y}$ ) of the EPG.

**Step 4: Calculate the operating margin emission factor according to the selected method**

The average OM emission factor ( $EF_{grid,OM-ave,y}$ ) is calculated as the average emission rate of all power plants serving the grid, using the methodological guidance as described under (a) above for the simple OM, but including in all equations also low-cost/must-run power plants. It may be calculated:

The average OM may be calculated:

Option A: Based on the net electricity generation and a CO<sub>2</sub> emission factor of each power unit; or

Option B: Based on the total net electricity generation of all power plants serving the system and the fuel types and total fuel consumption of the project electricity system.

Option B can only be used if:

- (a) The necessary data for Option A is not available; and
- (b) Only nuclear and renewable power generation are considered as low-cost/must-run power sources and the quantity of electricity supplied to the grid by these sources is known; and
- (c) Off-grid power plants are not included in the calculation (i.e., if Option I has been chosen in Step 2).

First, the data on net electricity generation, the average efficiency of each power unit and the fuel type(s) used in each power unit are not available in DPR Korea. Thus, the Option A cannot be adopted for the project.

Second, According to the definition of the DNA, only hydro power generation are considered as low-cost / must-run power sources. And the quantity of electricity supplied to the grid by low-cost / must-run power sources is known.

Third, Off-grid power plants are not included in the calculation.

Therefore, the Option B is adopted to calculate the average OM emission factor of the EPG.

Under this option, the average OM emission factor is calculated based on the net electricity supplied to the grid by all power plants serving the system, including low-cost/must-run power plants/units, and based on the fuel type(s) and total fuel consumption of the project electricity system, as follows:

$$EF_{grid,OM-ave,y} = \frac{\sum_i (FC_{i,y} \cdot NCV_{i,y} \cdot EF_{CO_2,i,y})}{EG_y} \quad (2)$$

Where:

- $EF_{grid,OM-ave,y}$  = Average operating margin CO<sub>2</sub> emission factor in year  $y$  (tCO<sub>2</sub>/MWh)
- $FC_{i,y}$  = Amount of fossil fuel type  $i$  consumed in the project electricity system in year  $y$  (mass or volume unit)
- $NCV_{i,y}$  = Net calorific value (energy content) of fossil fuel type  $i$  in year  $y$  (GJ/mass)

## CDM – Executive Board

	or volume unit)
$EF_{CO_2,i,y}$	= CO <sub>2</sub> emission factor of fossil fuel type $i$ in year $y$ (tCO <sub>2</sub> /GJ)
$EG_y$	= Net electricity generated and delivered to the grid by all power sources serving the system, including low-cost/must-run power plants/units, in year $y$ (MWh)
$I$	= All fossil fuel types combusted in power sources in the project electricity system in year $y$
$Y$	= The relevant year as per the data vintage chosen in Step 3

The Average OM emission factor is calculated ex-ante as a 3-year average (2007-2009):

$EF_{grid,OM,-ave,y} = 0.883,3 \text{ tCO}_2/\text{MWh}$  (details of the calculations are provided in Annex 3)

**Step 5: Calculate the build margin (BM) emission factor**

In terms of vintage of data, Option 1 is chosen to calculate the BM emission factor ( $EF_{grid,BM,y}$ ) of the EPG. Option 1 is described as follow:

**Option 1:** For the first crediting period, calculate the build margin emission factor ex ante based on the most recent information available on units already built for sample group  $m$  at the time of CDM-PDD submission to the DOE for validation. For the second crediting period, the build margin emission factor should be updated based on the most recent information available on units already built at the time of submission of the request for renewal of the crediting period to the DOE. For the third crediting period, the build margin emission factor calculated for the second crediting period should be used. This option does not require monitoring the emission factor during the crediting period.

The sample group of power units  $m$  used to calculate the build margin should be determined as per the following procedure, consistent with the data vintage selected above:

- Identify the set of five power units, excluding power units registered as CDM project activities, that started to supply electricity to the grid most recently ( $SET_{5-units}$ ) and determine their annual electricity generation ( $AEG_{SET-5-units}$ , in MWh);
- Determine the annual electricity generation of the project electricity system, excluding power units registered as CDM project activities ( $AEG_{total}$ , in MWh). Identify the set of power units, excluding power units registered as CDM project activities, that started to supply electricity to the grid most recently and that comprise 20% of  $AEG_{total}$  (if 20% falls on part of the generation of a unit, the generation of that unit is fully included in the calculation) ( $SET_{\geq 20\%}$ ) and determine their annual electricity generation ( $AEG_{SET-\geq 20\%}$ , in MWh);
- From  $SET_{5-units}$  and  $SET_{\geq 20\%}$  select the set of power units that comprises the larger annual electricity generation ( $SET_{sample}$ ); Identify the date when the power units in  $SET_{sample}$  started to supply electricity to the grid. If none of the power units in  $SET_{sample}$  started to supply electricity to the grid more than 10 years ago, then use  $SET_{sample}$  to calculate the build margin. Ignore steps (d), (e) and (f).

Otherwise:

- Exclude from  $SET_{sample}$  the power units which started to supply electricity to the grid more than 10 years ago. Include in that set the power units registered as CDM project activity, starting with power units that started to supply electricity to the grid most recently, until the electricity generation of the new set comprises 20% of the annual electricity generation of the project electricity system (if 20% falls on part of the generation of a unit, the generation of that unit is fully included in the calculation) to the extent is possible. Determine for the resulting set ( $SET_{sample-CDM}$ ) the annual electricity generation ( $AEG_{SET-sample-CDM}$ , in MWh);

## CDM – Executive Board

If the annual electricity generation of that set is comprises at least 20% of the annual electricity generation of the project electricity system (i.e.  $AEG_{SET\_sample-CDM} \geq 0.2 \times AEG_{total}$ ), then use the sample group  $SET_{sample-CDM}$  to calculate the build margin. Ignore steps (e) and (f).

Otherwise:

- (e) Include in the sample group  $SET_{sample-CDM}$  the power units that started to supply electricity to the grid more than 10 years ago until the electricity generation of the new set comprises 20% of the annual electricity generation of the project electricity system (if 20% falls on part of the generation of a unit, the generation of that unit is fully included in the calculation);
- (f) The sample group of power units  $m$  used to calculate the build margin is the resulting set ( $SET_{sample-CDM->10yrs}$ ).

In the EPG, none of the power units were installed to supply electricity to the grid within 10 years. So the sample group of power units  $m$  used to calculate the build margin chosen  $SET_{sample-CDM->10yrs}$ . However, the data of power units is not available to the public. The calculation of build margin emissions factor is not adopted in this PDD.

$$EF_{grid,BM,y} = 0 \text{ tCO}_2/\text{MWh} \quad (3)$$

**STEP 6: Calculate the combined margin (CM) emissions factor**

The calculation of the combined margin (CM) emission factor ( $EF_{grid,CM,y}$ ) is based on one of the following methods:

- (a) Weighted average CM; or  
 (b) Simplified CM.

The weighted average CM method (option A) should be used as the preferred option.

The simplified CM method (option b) can only be used if:

- The project activity is located in a Least Developed Country (LDC) or in a country with less than 10 registered projects at the starting date of validation; and
- The data requirements for the application of step 5 above cannot be met.

As described above, this project activity is located in a country with less than 10 registered projects at the starting date of validation and the data requirements for the application of step 5 cannot be met. Thus the simplified CM method can be used.

The combined margin is calculated using equation (4) with the following conditions:

- $W_{BM} = 0$ ;
- $W_{OM} = 1$ ;

Under the simplified CM, the operating margin emission factor ( $EF_{grid,OM,y}$ ) must be calculated using the average OM.

$$EF_{grid,CM,y} = EF_{grid,OM,y} \times W_{OM} + EF_{grid,BM,y} \times W_{BM} \quad (4)$$

Where

$EF_{grid,CM,y}$	= Combined Margin (CM) CO <sub>2</sub> emission factor in year y (tCO <sub>2</sub> /MWh)
$EF_{grid,BM,y}$	= Build margin CO <sub>2</sub> emission factor in year y (tCO <sub>2</sub> /MWh)
$EF_{grid,OM,y}$	= Operation margin CO <sub>2</sub> emission factor in year y (tCO <sub>2</sub> /MWh)



CDM – Executive Board

$W_{OM}$  = Weighting of operation margin emissions factor (%)

$W_{BM}$  = Weighting of build margin emissions factor (%)

$$EF_{grid, CM, y} = 1 \times 0.883,3 + 0 = 0.883,3 \text{ tCO}_2/\text{MWh}$$

### Project emissions

For most renewable energy project activities,  $PE_y = 0$ . However, for the following categories of project activities, project emissions have to be considered following the procedure described in the most recent version of ACM0002 (Version 12.3.0, EB 66).

- Emissions related to the operation of geothermal power plants (e.g. non-condensable gases, electricity/fossil fuel consumption)
- Emissions from water reservoirs of hydro power plants

According to the ACM0002 (Version 12.3.0, EB66), some project activities may involve project emissions that can be significant. These emissions shall be accounted for as project emissions by using the following equation.

$$PE_y = PE_{FF,y} + PE_{GP,y} + PE_{HP,y} \quad (5)$$

Where:

$PE_y$  = Project emissions in year y (tCO<sub>2</sub>e/yr)

$PE_{FF,y}$  = Project emissions from fossil fuel consumption in year y (tCO<sub>2</sub>/yr)

$PE_{GP,y}$  = Project emissions from the operation of geothermal power plants due to the release of non-condensable gases in year y (tCO<sub>2</sub>e/yr)

$PE_{HP,y}$  = Project emissions from water reservoirs of hydro power plants in year y (tCO<sub>2</sub>e/yr)

For hydropower project, since it is no fossil fuel consumption and not a geothermal power plant due to the release of non-condensable gases in year y (tCO<sub>2</sub>e/yr), so  $PE_{FF,y}$  and  $PE_{GP,y}$  is zero. As for  $PE_{HP,y}$ , it is justified subject to calculation of Power Density (PD).

According to methodology, hydro power project activities that result in new reservoirs and hydro power project activities that result in the increase of existing reservoirs, project proponents shall account for CH<sub>4</sub> and CO<sub>2</sub> emissions from the reservoir, estimated as follows:

If the power density of PD is greater than 10 W/ m<sup>2</sup>:

$$PE_{HP,y} = 0 \quad (6)$$

Since for the proposed project, PD is 73.68 W/ m<sup>2</sup>, which is well above 10 W/ m<sup>2</sup>, thus  $PE_{HP,y} = 0$

The power density of the project activity is calculated as follows:

$$PD = \frac{Cap_{PJ} - Cap_{BL}}{A_{PJ} - A_{BL}} \quad (7)$$

Where:

$PD$  = Power density of the project activity, in W/m<sup>2</sup>

$CAP_{PJ}$  = Installed capacity of the hydro power plant after the implementation of the project activity (W)

CDM – Executive Board

- $CAP_{BL}$  = Installed capacity of the hydro power plant before the implementation of the project activity (W). For new hydro power plants, this value is zero
- $A_{PJ}$  = Area of the reservoir measured in the surface of the water, after the implementation of the project activity, when the reservoir is full (m<sup>2</sup>)
- $A_{BL}$  = Area of the reservoir measured in the surface of the water, before the implementation of the project activity, when the reservoir is full (m<sup>2</sup>). For new reservoirs, this value is zero. Since the power density is calculated as follows:

$$\text{Power density} = \text{Installed capacity}/\text{Inundated area} = 14 \text{ MW}/0.19 \text{ km}^2 = 73.68 \text{ W/m}^2$$

**Leakage**

If the energy generating equipment is transferred from another activity, leakage is to be considered.

For the proposed project, leakage is zero, because there is no transfer of energy generating equipment.

$$LE_y = 0 \quad (8)$$

**Emission reductions**

Emission reductions are calculated as follows:

$$ER_y = BE_y - PE_y - LE_y \quad (9)$$

Where:

- $ER_y$  = Emission reductions in year y (tCO<sub>2</sub>/y)
- $BE_y$  = Baseline Emissions in year y (tCO<sub>2</sub>/y)
- $PE_y$  = Project emissions in year y (tCO<sub>2</sub>/y)
- $LE_y$  = Leakage emissions in year y (tCO<sub>2</sub>/y)

For the proposed project, emission reductions are as follows;

$$ER_y = BE_y \quad (10)$$

<b>B.6.2. Data and parameters that are available at validation:</b>
---

<b>Data / Parameter:</b>	$FC_{i,y}$
Data unit:	<b>1,000t/yr</b>
Description:	The amount of fuel <i>i</i> consumed by the power plants serving to the EPG in in year 2007, 2008 and 2009.
Source of data used:	Central Bureau of Statistics, 2008-2010
Value applied:	Refer to Annex 3
Justification of the choice of data or description of measurement methods and procedures actually applied :	Official national statistical data

CDM – Executive Board

Any comment:	-
--------------	---

<b>Data / Parameter:</b>	$NCV_{i,y}$
Data unit:	<b>TJ /Gg</b>
Description:	Net calorific value (energy content) per mass or volume unit of a fuel <i>i</i>
Source of data used:	Table 1.2 of Chapter 1 of Vol. 2 (Energy) of the 2006 IPCC Guidelines on National GHG Inventories
Value applied:	Refer to Annex 3
Justification of the choice of data or description of measurement methods and procedures actually applied :	According to the “Tool to calculate the emission factor for an electricity system” , 2006 IPCC defaults values can be used;  Once for each crediting period using the most recent three historical years for which data is available at the time of submission of the CDM-PDD to the DOE for validation (ex-ante option)
Any comment:	

<b>Data / Parameter:</b>	$EF_{CO_2,i,y}$
Data unit:	<b>tCO<sub>2</sub>/TJ</b>
Description:	The CO <sub>2</sub> emission factor per unit of energy of the fuel <i>i</i>
Source of data used:	Defaults in table 1.4 of Chapter 1 of Vol.2 (Energy) of the 2006 IPCC Guidelines for National Greenhouse Gas Inventories
Value applied:	Refer to Annex 3
Justification of the choice of data or description of measurement methods and procedures actually applied :	IPCC default value is used because no country specific value is available.
Any comment:	

<b>Data / Parameter:</b>	$w_{OM}; w_{BM}$
Data unit:	-
Description:	The weights of $EF_{OM,y}$ and $EF_{BM,y}$ for hydropower projects
Source of data used:	“Tool to calculate the emission factor for an electricity system” (Version 02.2.1, EB 63)
Value applied:	$w_{OM}=1; w_{BM}=0$
Justification of the choice of data or description of	This project activity is located in a country with less than 10 registered projects at the starting date of validation and the data requirements for the application of step 5 of guidance cannot be met. Thus, these values are used.

CDM – Executive Board

measurement methods and procedures actually applied :	
Any comment:	

<b>Data / Parameter:</b>	$EG_y$
Data unit:	<b>GWh</b>
Description:	Net electricity generated and delivered to the grid by all power sources serving the system, including low-cost/must-run power plants/units, in year y.
Source of data used:	Central Bureau of statistic
Value applied:	Refer to Annex 3
Justification of the choice of data or description of measurement methods and procedures actually applied :	Official statistical data
Any comment:	-

**B.6.3. Ex-ante calculation of emission reductions:**

&gt;&gt;

According to section B.6.1 and further details in Annex 3, the combined baseline emission factor of the project is 0.883,3 tCO<sub>2</sub>e/MWh in the crediting period. And the annual electricity delivered to the EPG by the project is 53,990 MWh/yr.

**Calculation of baseline emission ( $BE_y$ )**

In the first crediting period,  $BE_y$  is calculated as follows:

$$BE_y = 53990 \text{ MWh} \times 0.8833 \text{ tCO}_2 / \text{MWh} = 47689 \text{ tCO}_2 e$$

**Calculation of project emission ( $PE_y$ )**

As mentioned in the B.6.1,  $PE_y = 0$

**Calculation of leakage ( $LE_y$ )**

As mentioned in the B.6.1,  $LE_y = 0$

**Calculation of emission reduction ( $ER_y$ )**

$$ER_y = BE_y - PE_y - LE_y = 47689 \text{ tCO}_2 e$$

CDM – Executive Board

**B.6.4 Summary of the ex-ante estimation of emission reductions:**

&gt;&gt;

The total emission reductions of the project are 476,894 tCO<sub>2</sub>e during the first crediting period.

Table 9 Estimate of Emission Reductions due to the Project

Year	Estimation of project activity emissions (tCO <sub>2</sub> e)	Estimation of baseline emissions (tCO <sub>2</sub> e)	Estimation of leakage (tCO <sub>2</sub> e)	Estimation of overall emission reductions (tCO <sub>2</sub> e)
01/01/2014-31/12/2014	0	47,689	0	47,689
01/01/2015-31/12/2015	0	47,689	0	47,689
01/01/2016-31/12/2016	0	47,689	0	47,689
01/01/2017-31/12/2017	0	47,689	0	47,689
01/01/2018-31/12/2018	0	47,689	0	47,689
01/01/2019-31/12/2019	0	47,689	0	47,689
01/01/2020-31/12/2020	0	47,689	0	47,689
01/01/2021-31/12/2021	0	47,689	0	47,689
01/01/2022-31/12/2022	0	47,689	0	47,689
01/01/2023-31/12/2023	0	47,689	0	47,689
<b>Total(tCO<sub>2</sub>e)</b>	0	476,894	0	476,894

**B.7. Application of the monitoring methodology and description of the monitoring plan:****B.7.1 Data and parameters monitored:**

&gt;&gt;

<b>Data / Parameter:</b>	<b>EG<sub>facility,y</sub></b>
Data unit:	<b>MWh/yr</b>
Description:	Quantity of net electricity generation supplied by the project plant to the grid in year y
Source of data to be used:	Project activity site
Value of data applied for the purpose of calculating expected emission reductions in section B.5	53,990
Description of	Electricity will be measured directly and continuously by meters with SCADA

CDM – Executive Board

measurement methods and procedures to be applied:	system. Recording frequency will be hourly measurement and monthly recording; data will be archived at the end of each month using the electronic spreadsheet; the electronic files will be stored on hard disk and CD-ROM; in addition a hard copy printout will be archived; all data records will be kept until 2 years after the end of the crediting period or the last issuance of CERs. Calibration should be undertaken as prescribed by Quality Supervising Institution, DPR Korea.
QA/QC procedures to be applied:	Establish a monitoring team; constitute detailed obligation for monitoring; introduce precision meters; install five meters connected computer; all meters will have the capability to read remotely through a communication line; and keep the electricity sale receipt as a hard proof for data quality control.
Any comment:	-

<b>Data / Parameter:</b>	$A_{PJ}$
Data unit:	$\text{km}^2$
Description:	Area of the reservoir measured in the surface of the water, after the implementation of the project activity, when the reservoir is full.
Source of data to be used:	Project site
Value of data applied for the purpose of calculating expected emission reductions in section B.5	0.19
Description of measurement methods and procedures to be applied:	Measured from topographical surveys and maps
QA/QC procedures to be applied:	-
Any comment:	-

### **B.7.2. Description of the monitoring plan:**

&gt;&gt;

The monitoring plan is developed in accordance with the modalities and procedures for small-scale CDM project activities. The objective of the monitoring plan is to ensure the complete, consistent, clear and accurate monitoring and calculation of the emissions reductions during the whole crediting period.

Baseline emission factor of the project is determined as ex-ante. Therefore the electricity delivered by the project to the EPG is defined as the key data to be monitored.

Emission reductions resulted from the project activity will be calculated based on the net energy export to the grid in accordance with the calculation illustrated in Section B.6.3 of the PDD. Emission reductions generated by the project shall be monitored at regular intervals.

#### **1. Monitoring organization**

A monitoring team will be organized by the project owner.

## CDM – Executive Board

The obligation of monitoring team is;

- to establish the SCADA system,
- to conduct automatic measurement & records by computer, and
- to calculate emission reductions and prepare a monitoring report.

An agreement will be signed between the project owner and the distribution station that defines the metering arrangements and the required quality control procedures to ensure accuracy. According to the national law<sup>16</sup>, the electric energy metering equipment will be properly installed and checked by both the project owner and the distribution station before the operation of the project.

## 2. Installation of meters

The net electricity supplied to the grid by the project would be determined through calculating the difference between the electricity supplied to and delivered from the grid by the project. All those data would be continuously monitored by the meters located at the monitoring spot both agreed by the project owner and the grid company. Two meters are required, of which, M2 (backup meter) at the exit of the project station is employed to measure output electricity, and M1 (main meter) measures the power supplied to the grid at the input of the substation of the Grid Company. All the meters have function of automatic measurement of electric power, back up and bidirectional measurement.

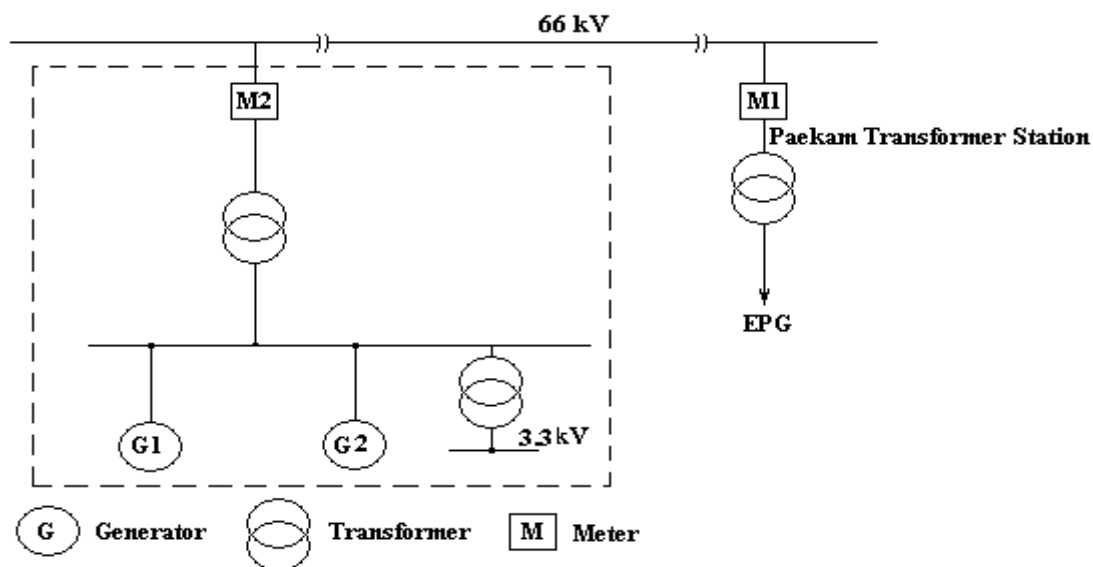

Figure 3. Location of the meters

All meters will have capability to read remotely through a communication line. The data should be cross-checked against relevant electricity sale receipts and/or records from the grid.

The project owner should ensure that the meter readings be readily available for DOE's verification.

## 3. Calibration

<sup>16</sup> Law of DPR Korea on Management of Energy, 5 August 2008, Law Publishing Company

Calibration of the meters should be implemented according to the national standard and regulation<sup>17</sup> periodically.

The meters shall have sufficient accuracy so that any errors resulting from such equipment shall not exceed + (-) 0.5% of full-scale rating.

Before the installation of meters, meters should be calibrated by the qualified institution co-authorized by the project owner and the distribution station.

The calibrator will seal the equipment which is passed through the test calibration. After he conducted its calibration he will prepare the calibration tables and record the test value and other items. The calibrated equipment will be sealed in the presence of both the project owner and the distribution station. If any of party is not presented, then the equipment will not be sealed or replaced. In case there is a big allowable error in the meters, the equipment will be repaired or replaced with other calibrated equipment.

#### **4. Data recording procedure**

The process for collecting the electricity meter data will be detailed in a procedure. A summary of this procedure is provided below.

- a) At the end of each month, the monitoring team and the grid company will take a meter reading and record this figure.
- b) The grid company and monitoring team will inform the project owner the electricity amount for settlement. The project owner will crosscheck the figures in comparison with the data from backup meter and based on their own professional experiences.
- c) Both the project owner and the grid company will agree on the electricity amount and the project company will issue the invoice containing the specific amount of electricity for settlement.

#### **5. Data Management System**

Data will be archived at the end of each month using the electronic spreadsheet. The electronic files will be stored on hard disk and CD-ROM. In addition a hard copy printout will be archived. The project owner will reserve the sale and purchasing invoices, and at the end of each year will prepare a monitoring report for DOE. The monitoring report includes a monitoring and checking report of electricity supplied to the grid, a calculation report of emission reduction, and maintaining and calibration records of monitoring machines, etc.

In order to facilitate auditor's reference, monitoring results will be indexed. All paper-based information will be stored by project owner. The monitoring reports will be reviewed by the General Manager.

All data records will be kept until 2 years after the end of the crediting period or the last issuance of CERs.

#### **6. Training**

The officers relevant to monitoring will attend a training session by the CDM consultants. The training session will include the following:

- Basic concept of CDM
- Monitoring plan
- Monitoring procedures

---

<sup>17</sup> “Technical Regulation on Electric Equipment”, 2005, Ministry of Electricity and Coal Industry



CDM – Executive Board

- Method of metering and calibration
- Audit procedures
- Worksheet (excel) containing monitoring data and calculations
- Monitoring report template
- Practical training exercise

**B.8. Date of completion of the application of the baseline study and monitoring methodology and the name of the responsible person(s)/entity(ies):**

>>

The whole study of the project was completed on 20 January 2011 by Institute of Thermal Engineering, SAoS.

The persons involved in the study are listed as follows:

1. Mr. Mansu Kwak, Senior Researcher, Institute of Thermal Engineering, SAoS, Moranbong district, Pyongyang, DPR Korea, E-mail Add: pptayang@star-co.net.kp, Tel: 850-2-3818111/ext-8544, FAX: 850-2-3814410/2100

2. Mr. Ulsong Kim, Project officer, SAoS, Moranbong district, Pyongyang, DPR Korea, E-mail Add: pptayang@star-co.net.kp, Tel: 850-2-3818111/ext-8544, FAX: 850-2-3814410/2100  
(they are not project participants).

**SECTION C. Duration of the project activity / crediting period**

**C.1. Duration of the project activity:**

**C.1.1. Starting date of the project activity:**

>>

07/10/2010 (Construction Contract was signed.)

**C.1.2. Expected operational lifetime of the project activity:**

>>

20 years

**C.2. Choice of the crediting period and related information:**

**C.2.1. Renewable crediting period:**

Not applicable

**C.2.1.1. Starting date of the first crediting period:**

>>

Not applicable

CDM – Executive Board

<b>C.2.1.2. Length of the first crediting period:</b>
---

&gt;&gt;

Not applicable

<b>C.2.2. Fixed crediting period:</b>
---------------------------------------

<b>C.2.2.1. Starting date:</b>
--------------------------------

&gt;&gt;

01/01/2014 (or earliest date after registration)

<b>C.2.2.2. Length:</b>
-------------------------

&gt;&gt;

10 years

<b>SECTION D. Environmental impacts</b>
---

&gt;&gt;

<b>D.1. Documentation on the analysis of the environmental impacts, including transboundary impacts:</b>
--

&gt;&gt;

Based on the Law of DPR Korea on EIA<sup>18</sup>, the Environmental Impact Assessment (EIA) should be completed before the development and construction of the proposed project. Thus, the project owner authorized a third party to carry out the EIA report. The EIA report was completed by Environment and Development Centre on 13 August 2009<sup>19</sup> and approved by the Bureau of Land and Environmental Protection, People's Committee of Ryanggang Province, DPR Korea, on 24 October 2009<sup>20</sup>.

Synthesizing the result of EIA on the construction and operation of the project is as follows.

**1) Air quality**

At the construction stage, it may cause air pollution due to the exhaust gas and dust in the process of excavation and operation of transport vehicles. Watering the transport routes and undertaking necessary repair and replace of the rolling machinery which emits lots of exhaust gas will be carried out to reduce the air pollution produced during the construction period.

During the operation of the project, there is no air pollution source.

**2) Water quality**

At the construction stage, it discharges the engineering wastewater from the concrete mixing ground and the repair place of machinery and some domestic sewage from employees who are involved in the engineering work. In order to reduce water pollution due to residuary water, the septic tanks and deposit

<sup>18</sup> Law of DPR Korea on Environmental Impact Assessment, 5 August 2008, Law Publishing Company.

<sup>19</sup> Environmental Impact Assessment Report, August 2009, Environment and Development Centre, Ministry of Land and Environment Protection

<sup>20</sup> Licence for Approval of Environmental Impact Assessment Report, 24 October 2009, Bureau of Land and Environmental Protection, People's Committee, Ryanggang Province

CDM – Executive Board

ponds will be installed to meet the environmental standard and then the wastewater will be discharged into the natural streams. During the operation of the project, oil wastewater produced from the maintenance of equipment will be treated through oil collection and separation by the separator before discharging into the river. The domestic sewage caused by employees of the plant will be processed in several septic tanks.

### 3) Noise

At the construction stage, the noise is mainly caused by the excavation and blasting and operation of the machines which are used in the engineering work. In order to reduce the noise impact to the maximum, it will adjust the blasting hour and examine the machines and the affected employees who are involved in engineering work will be worn earplugs.

### 4) Solid waste

Solid waste occurred at the construction stage is debris produced from the excavation of the pits and domestic garbage from employees who are involved in the engineering work. The debris will be reused as materials for dam construction through the primary processing and the domestic garbage will be disposed in the burial ground in order to minimize the impact.

### 5) Impact on ecosystem

There is no reserve or protected animals around the project construction and the project construction gives little impact on the surrounding ecosystem. During the operation period, a certain ecological water discharge will be maintained to sustain aquatic ecosystem in downstream.

### 6) Impact on social economy

Due to the construction and operation of the project, some families will be resettled and there are no flooded farmlands. The project owner will be responsible for building new dwelling houses for the resettled residents.

In general, there will be no negative impact of the project on the surrounding environment.

**D.2. If environmental impacts are considered significant by the project participants or the host Party, please provide conclusions and all references to support documentation of an environmental impact assessment undertaken in accordance with the procedures as required by the host Party:**

>>

For suitable measures for environment, as mentioned above, the environmental effects by the project are not great.

## SECTION E. Stakeholders' comments

>>

**E.1. Brief description how comments by local stakeholders have been invited and compiled:**

>>

Before the starting of project construction, Namgang Hydropower Construction Complex requested to the People's Committee of Paekam County to survey comments from the peoples who will be affected by the

project. The People's Committee of Paekam County distributed a questionnaire<sup>21</sup> to 50 stakeholders on 16 October 2010. Questionnaire included the draft project description and several questions.

**Questionnaire's contents are as follows;**

1. Do you know about CDM and global warming?
2. Do you agree with the hydropower plant construction?
3. Will the project bring any benefits to the local residents?
4. Do you think the project will have positive impact on local economic?
5. Do you support the construction of the project?
6. How do you think of the environmental impact of the project to local area?
7. What negative impacts can be made by the project?

The People's Committee of Paekam County held the meeting for treating the comments from stakeholders at 3 o'clock on 26 October 2010<sup>22</sup>. The stakeholders in the upstream, downstream and powerhouse participated in meeting.

The meeting have informed the importance of the project, process of the project construction and resettlement plan.

**Questions from participants of the meeting are as follows;**

1. How far is the project site from resident area?
2. Where the flooded residents would be moved?
3. Do you have the resettlement plan?
4. How much land will be flooded by the project?
5. How can you compensate the land loss?
6. Dose the project take negative effect to resident's income?
7. When the power plant will be finished?

<b>E.2. Summary of the comments received:</b>
---

>>

50 of the distributed questionnaires were collected. 30% of the replied were high educated residents, and all stakeholders were above 25 years old.

The following is a summary of the key findings:

- All of the respondent know and agree the project construction;
- 100% of the respondents believe the project has positive impact on local economic development;
- All of the stakeholders agree that the project will benefit their daily life;
- Some respondents think that the local ecosystem will be little affected by the project; and

<sup>21</sup> Questionnaire relevant to the construction of Paekdusan Songun Youth Hydropower Project No.2, 16 October 2010

<sup>22</sup> Report for local stakeholder's comments, 26 October 2010, Paekam County People's Committee

---

CDM – Executive Board

- Most of the responders think that the project will not cause negative impact on local environment and ecosystem.

The survey shows that all stakeholders agreed with the construction of the project. The general opinions are: the construction of the power plant will have a limited influence on the local ecosystem if a series of practical measures are taken. Although some tilled land will be flooded, all of the local residents will obtain corresponding compensation. The project's impact is more positive than negative. Therefore, the local residents and government support the project construction.

<b>E.3. Report on how due account was taken of any comments received:</b>
---

>>

No negative comments have been received on the project. Moreover, the local community submitted very positive comments on the effects that the proposed project will improve the local economy and infrastructure.

CDM – Executive Board

**Annex 1****CONTACT INFORMATION ON PARTICIPANTS IN THE PROJECT ACTIVITY**

Organization:	Namgang Hydropower Construction Complex
Street/P.O.Box:	Samdung-ri, Kandong County, Pyongyang City, DPR Korea
Building:	
City:	Pyongyang
State/Region:	
Postcode/ZIP:	
Country:	Democratic People's Republic of Korea
Telephone:	850-2-381-5926
FAX:	850-2-381-4654
E-Mail:	<a href="mailto:gbcio@star-co.net.kp">gbcio@star-co.net.kp</a>
URL:	
Represented by:	Ri Yong Nam
Title:	Director, Carbon Trade Division
Salutation:	Mr
Last name:	Ri
Middle name:	
First name:	Yong Nam
Department:	Carbon Trade Division
Mobile:	
Direct FAX:	850-2-381-4654
Direct tel:	850-2-381-5926
Personal e-mail:	

CDM – Executive Board

Organization:	<b>Topič Energo s.r.o.</b>
Street/P.O.Box:	Pavelčákova 437/6 779 00 Olomouc, Czech Republic
Building:	
City:	
State/Region:	
Postcode/ZIP:	
Country:	Czech Republic
Telephone:	+420 731 688 910
FAX:	
E-Mail:	<a href="mailto:blazek@topic-energo.cz">blazek@topic-energo.cz</a>
URL:	<a href="http://www.topic-energo.cz">http://www.topic-energo.cz</a>
Represented by:	
Title:	
Salutation:	Mr
Last name:	Blažek
Middle name:	
First name:	Miroslav
Department:	
Mobile:	
Direct FAX:	
Direct tel:	+420 731 688 910
Personal e-mail:	<a href="mailto:blazek@topic-energo.cz">blazek@topic-energo.cz</a>

**Annex 2**

**INFORMATION REGARDING PUBLIC FUNDING**

There is no public funding from Annex I Parties for the project.



**Annex 3****BASELINE INFORMATION****Table 10. The ratio of power generated by thermal power and hydro power for EPG 2005-2009**

	2005	2006	2007	2008	2009
Electricity Generation of Thermal Power Plant (GWh)	9,753	9,499	9,268	9,547	100,26
Electricity Generation of Hydro Power Plant (GWh)	6,477	5,980	6,099	6,873	6,249
Other Power (GWh)	0	0	0	0	0
Total Electricity Generation of EPG (GWh)	16,230	15,479	15,367	16,420	16,275
The ratio of power generated by hydropower and other must run/low cost resources of total grid generation	39.9%	38.6%	39.7%	41.9%	38.4%

Data source: Central Bureau of Statistics 2006-2010, DPR Korea

**Table 11. Data for fuel consumption in thermal power plants of EPG in 2007**

	Unit	Pukchang	Chongjin
Anthracite	1,000 t	6,401	
Lignite	1,000 t		393
Residual Fuel oil	1,000 t	71.3	2.0

Data source: Central Bureau of Statistics 2008, DPR Korea

**Table 12. Data for fuel consumption in thermal power plants of EPG in 2008**

	Unit	Pukchang	Chongjin
Anthracite	1,000 t	6,676	
Lignite	1,000 t		451
Residual Fuel oil	1,000 t	72.2	3.1

Data source: Central Bureau of Statistics 2009, DPR Korea

**Table 13. Data for fuel consumption in thermal power plants of EPG in 2009**

	Unit	Pukchang	Chongjin
Anthracite	1,000 t	7,060	
Lignite	1,000 t		483
Residual Fuel oil	1,000 t	73.9	3.2

Data source: Central Bureau of Statistics 2010, DPR Korea

**Table 14. Thermal power generation supplied to the EPG in 2007**

	Unit	Electricity supplied to the grid
Chongjin	GWh	252
Pukchang	GWh	9,016
Total	GWh	9,268

Data source: Central Bureau of Statistics 2008, DPR Korea

CDM – Executive Board

**Table 15. Thermal power generation supplied to the EPG in 2008**

	Unit	Electricity supplied to the grid
Chongjin	GWh	288
Pukchang	GWh	9,259
Total	GWh	9,547

*Data source: Central Bureau of Statistics 2009, DPR Korea***Table 16. Thermal power generation supplied to the EPG in 2009**

	Unit	Electricity supplied to the grid
Chongjin	GWh	302
Pukchang	GWh	9,724
Total	GWh	10,026

*Data source: Central Bureau of Statistics 2010, DPR Korea***Table 17. The operating margin(OM) emission factor calculation of EPG in 2007**

Fuel	Unit	Fuel consumption in EPG A	EF (tC/TJ) B	NCV(GJ/t) C	CO <sub>2</sub> emissions (tCO <sub>2</sub> e) D=A*B*C*44/12 (mass unit)
Anthracite	1,000 t	6,401	25.8	21.6	13,079,547
Lignite	1,000 t	393	24.8	5.5	196,552
Residual Fuel oil	1,000 t	73.3	20.6	39.8	209,084
Total Emission E			13,485,184 tCO <sub>2</sub> e		
Total Electricity supplied to EPG F			15,367 GWh		
OM Emission Factor in 2007 G (=E/(F*1,000))			0.878 tCO <sub>2</sub> e/MWh		

*Data source: Central Bureau of Statistics 2008; 2006 IPCC Guidelines for National Greenhouse Gas Inventories: Table 1.4 of p. 1.23; p. 1.24 in Chapter one, Volume 2***Table 18. The operating margin(OM) emission factor calculation of EPG in 2008**

Fuel	Unit	Fuel consumption in EPG A	EF (tC/TJ) B	NCV(GJ/t) C	CO <sub>2</sub> emissions (tCO <sub>2</sub> e) D=A*B*C*44/12 (mass unit)
Anthracite	1,000 t	6,676	25.8	21.6	13,641,471
Lignite	1,000 t	451	24.8	5.5	225,560
Residual Fuel oil	1,000 t	75.3	20.6	39.8	214,789
Total Emission E			14,081,821 tCO <sub>2</sub> e		
Total Electricity supplied to EPG F			16,420 GWh		
OM Emission Factor in 2008 G (=E/(F*1,000))			0.858 tCO <sub>2</sub> e/MWh		

*Data source: Central Bureau of Statistics 2009; 2006 IPCC Guidelines for National Greenhouse Gas Inventories: Table 1.4 of p. 1.23; p. 1.24 in Chapter one, Volume 2***Table 19. The operating margin(OM) emission factor calculation of EPG in 2009**

Fuel	Unit	Fuel consumption in EPG A	EF (tC/TJ) B	NCV(GJ/t) C	CO <sub>2</sub> emissions (tCO <sub>2</sub> e) D=A*B*C*44/12 (mass unit)
Anthracite	1,000 t	7,060	25.8	21.6	14,426,122
Lignite	1,000 t	483	24.8	5.5	241,564
Residual	1,000 t	77.1	20.6	39.8	219,924

CDM – Executive Board

Fuel oil				
Total Emission E		14,887,610 tCO <sub>2</sub> e		
Total Electricity supplied to EPG F		16,275 GWh		
OM Emission Factor in 2009 G (=E/(F*1,000))		0.915 tCO <sub>2</sub> e/MWh		

Data source: Central Bureau of Statistics 2010; 2006 IPCC Guidelines for National Greenhouse Gas Inventories: Table 1.4 of p. 1.23; p. 1.24 in Chapter one, Volume 2

According to electricity supplied to the EPG, the OM of latest three years should be weighted average, so the weighted average OM is:

$$EF_{OM} = \frac{(0.878 \times 15,367,000 + 0.858 \times 16,420,000 + 0.915 \times 16,275,000)}{(15,367,000 + 16,420,000 + 16,275,000)} = 0.8833 \text{ tCO}_2\text{e} / \text{MWh}$$

The Build Margin Emission Factor is 0 tCO<sub>2</sub>/MWh.

The baseline emission factor was calculated as the weighted average of the OM Emission Factor (0.883,3 tCO<sub>2</sub>e/MWh) and the BM Emission Factor (0 tCO<sub>2</sub>e/MWh).

According to the methodology,  $w_{OM}=1$  and  $w_{BM}=0$ .

The baseline emission factor is then 0.883,3 tCO<sub>2</sub>e/MWh.

The emission factors of each year and average emission factor in the EPG are listed in Table 20.

Table 20. Emission factor in EPG

	2007	2008	2009	average
OM	0.878	0.858	0.915	0.883,3
BM	0.000	0.000	0.000	0.000
CM	0.878	0.858	0.915	0.883,3

---

CDM – Executive Board

**Annex 4**

**MONITORING INFORMATION**

No additional information.