

CLEAN DEVELOPMENT MECHANISM
PROJECT DESIGN DOCUMENT FORM (CDM-SSC-PDD)
Version 03 - in effect as of: 22 December 2006

CONTENTS

- A. General description of the small scale project activity
- B. Application of a baseline and monitoring methodology
- C. Duration of the project activity / crediting period
- D. Environmental impacts
- E. Stakeholders' comments

Annexes

Annex 1: Contact information on participants in the proposed small scale project activity

Annex 2: Information regarding public funding

Annex 3: Baseline information

Annex 4: Monitoring Information

References

Revision history of this document

Version Number	Date	Description and reason of revision
01	21 January 2003	Initial adoption
02	8 July 2005	<ul style="list-style-type: none">• The Board agreed to revise the CDM SSC PDD to reflect guidance and clarifications provided by the Board since version 01 of this document.• As a consequence, the guidelines for completing CDM SSC PDD have been revised accordingly to version 2. The latest version can be found at http://cdm.unfccc.int/Reference/Documents.
03	22 December 2006	<ul style="list-style-type: none">• The Board agreed to revise the CDM project design document for small-scale activities (CDM-SSC-PDD), taking into account CDM-PDD and CDM-NM.

CDM – Executive Board

SECTION A. General description of small-scale project activity
A.1 Title of the small-scale project activity:

>>

Title: Kumya Hydropower Plant

Version of document: Version 2.0

Date: 15/11/2011

Revision history of the document:

Version of document	Date of the document	Reason for revision
Version 1.0	01/08/2011	-
Version 2.0	15/11/2011	The document was revised according to the resolution of corrective action and clarification request of CEC.

A.2. Description of the small-scale project activity:

>>

The Kumya Hydropower Plant (hereafter referred to as “the Project”) is a reservoir-type power plant, which is newly built in Kumya County, South Hamgyong Province.

The purpose of this project activity is to generate clean form of electricity using the potential energy available in the water flows of Kumya River and supply the electricity to the Eastern Power Grid (EPG), DPR Korea /1/.

The total installed capacity of the Project is 7.5 MW (2.5 MW×3). The Project will supply the electricity of 22.5 GWh to the EPG annually /1/. The annual operating time is 3,080 h. The electricity would be generated at 6.6 kV and transmitted to 66 kV Kumya Substation which is connected to the EPG.

After all the turbines and generators are put into operation on 1 January 2013, the Project will displace part of thermal power in EPG by making use of clean and renewable energy, thus achieving GHG emission reductions of 19,874 tCO₂e annually.

The Project will bring positive impacts on local community in social, economic and environmental aspects /5/:

- Project activity will be consistent with the national energy policy of DPR Korea and Kumya County’s development strategy.
- Several tens of people will be permanently employed for the project operation, and during the construction period of the Project, many jobs will be created transiently.
- Business activities of project owner and other enterprises related to the construction of hydropower plant will be improved in the local area.
- Project activity will reduce the fossil fuel consumption and promote the use of renewable energy

CDM – Executive Board

and the diversification of the economic structure in Kumya County compared to a business-as-usual scenario.

In conclusion, the project activity strongly contributes to the sustainable development in DPR Korea.

A.3. Project participants:

>>

Name of Party involved(*) ((host) indicates a host party)	Private and/or public entity(ies) Project participants(*) (as applicable)	Kindly indicate if the Party involved wishes to be considered as project participant(Yes/No)
Democratic People's Republic of Korea(host)	Kumya Hydropower Plant Operation and Construction Company (KHPOCC)	No
Czech Republic	Topič Energo s.r.o.	No

Detailed contact information for project participants is available in Annex 1.

A.4. Technical description of the small-scale project activity:

>>

A.4.1. Location of the small-scale project activity:

>>

A.4.1.1. Host Party (ies):

>>

Democratic People's Republic of Korea

A.4.1.2. Region/State/Province etc.:

>>

South Hamgyong Province

A.4.1.3. City/Town/Community etc:

>>

Kumya County/ Ryongwon-ri

A.4.1.4. Details of physical location, including information allowing the unique identification of this small-scale project activity :

>>

The Project is located in Ryongwon-ri, Kumya County, South Hamgyong Province, DPR Korea. The project site can be accessed through Pyongyang-Hamhung expressway and the distance from Pyongyang to the Project is 293 km along that way. The nearest railway station is Jongpyong station. The detailed geographical coordinates of the project site are 39°34'22"N latitude and 127°07'08" E longitude. To visualize the exact location of the project, refer to the map in figure1.



Figure 1. Location of the Project

A.4.2. Type and category (ies) and technology/measure of the small-scale project activity:

>>

1. Type and category (ies) of the small-scale project activity

According to the categorization of Appendix B of the Simplified Modalities and Procedures for Small-scale CDM Project Activities, the type and category of the Project are defined as follows:

Type I: Renewable energy projects

Category I.D: Renewable Energy Generation for a Grid

Sub-category: Hydro

Reference: AMS-I.D, Version 17, EB 61

The Project will produce the electricity by the renewable energy and displace electricity from the EPG that is supplied by several fossil fuel fired generating units. The capacity of the Project will be 7.5 MW within the threshold capacity of 15 MW. The electricity generated by the Project will be transmitted to the EPG through the Kumya Substation. Accordingly, the applicable methodology for the project activity shall be AMS-I.D.

2. Technologies applied on the small-scale project activity /1/

The Project is a reservoir-type power plant. The Project is consisted of a dam, a powerhouse and a substation etc. The length and height of dam is 600 m and 11m, respectively and the dam is built with the concrete dam and the rock-filled dam. Three sets of low water head generating facilities with capacity of 2.5 MW, which are made by Ryongsong Machine Complex, are used in the proposed hydropower plant. The electricity produced by the proposed plant will be supplied to the Kumya Substation through the out door substation. The Kumya Substation is the substation connected to the EPG, DPR Korea. The proposed hydropower plant will supply the electricity of 22.5 GWh to the EPG every year. Figure 2 and table 1 shows the layout of the Project and technical parameters of the hydropower turbines and hydropower generators.

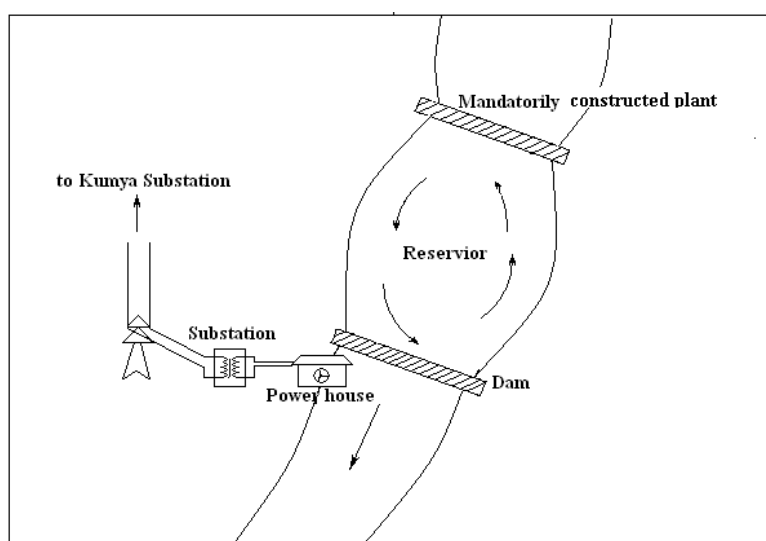

Figure2. Layout of the project activity

Table.1 Main parameters of hydropower turbines and generators

Item	Unit	Values
Turbines		
Type		370-V277
Quantity	set	3
Rated speed	rpm	150
Designed water head	m	8
Manufacturer		Ryongsong Machine Complex (RMC)
Generators		
Type		SVL2.5 MW-66 kV
Quantity	set	3
Frequency	Hz	60
Manufacturer		Ryongsong Machine Complex (RMC)

3. Environmentally Safe Technology

The technologies applied in the Project have been generalized in the world and are environmentally friendly.

The technology used in the Project is environmentally safe. Characteristics of the hydropower plant and its construction method will not give any negative impacts on the ecosystem. Moreover, it will allow the

CDM – Executive Board

Project to conserve the biodiversity of this particular zone along the river.

4. Technology transfer

The main equipment, such as turbines and generators, are manufactured in the host country. No technology transferred from other countries is involved in this project activity. RMC will be responsible for producing facilities. This RMC is well known as the base of specially producing machines and electric equipment in DPR Korea.

A.4.3 Estimated amount of emission reductions over the chosen crediting period:

>>

The crediting period of the project activity is 10 years, which is from 1 January 2013 to 31 December 2022. During the crediting period, the total emission reductions are estimated to be 198,740 tCO₂e. The annual and total emission reductions are explained in the following table 2:

Table.2 Estimation of emission reductions during crediting period

Years	Annual estimation of emission reductions in (tCO ₂ e)
01/01/2013 - 31/12/2013	19,874
01/01/2014 - 31/12/2014	19,874
01/01/2015 - 31/12/2015	19,874
01/01/2016 - 31/12/2016	19,874
01/01/2017 - 31/12/2017	19,874
01/01/2018 - 31/12/2018	19,874
01/01/2019 - 31/12/2019	19,874
01/01/2020 - 31/12/2020	19,874
01/01/2021 - 31/12/2021	19,874
01/01/2022 - 31/12/2022	19,874
Total estimated reductions (tonnes of CO ₂ e)	198,740
Total number of crediting years	10
Annual average over the crediting period of estimated reductions (tonnes of CO ₂ e)	19,874

A.4.4. Public funding of the small-scale project activity:

>>

No public funding from parties included in Annex I of UNFCCC is available to the project activity.

A.4.5. Confirmation that the small-scale project activity is not a debundled component of a large scale project activity:

>>

According to the Appendix C of the Simplified Modalities and Procedures for small-scale CDM project activities, the Project is not a debundled component of a larger project activity because there is not a registered small-scale CDM project activity or an application to register another small-scale CDM activity:

- With the same project participants;

CDM – Executive Board

- In the same project category and technology/measure;
- Registered within the previous 2 years;
- Whose project boundary is within 1 km of the project boundary of the proposed small scale activity at the closest point.

There is Kumya hydropower plant No.1 within the distance of 4 km upstream from the proposed plant. This is attractive economically and on construction. The project owner confirmed that the project owner of Kumya hydropower plant No.1 did not apply to register the plant as CDM project so far and will not apply in future. Therefore, the Project is not a debundled component of a larger project activity.

SECTION B. Application of a baseline and monitoring methodology

>>

B.1. Title and reference of the approved baseline and monitoring methodology applied to the small-scale project activity:

>>

The methodology applied for the proposed project is the approved methodology for small-scale CDM project- “AMS-I.D Grid connected renewable electricity generation” (Version 17, EB 61) and “Tool to calculate the emission factor for an electricity system (Version 02.2.1, EB 63)”. For more information regarding the methodology, please refer to the link:

<http://cdm.unfccc.int/methodologies/SSCmethodologies/approved.html>

<http://cdm.unfccc.int/methodologies/PAmethodologies/approved.html>

B.2 Justification of the choice of the project category:

>>

The project activity meets all the applicability conditions of the AMS-I.D (Version 17, EB 61) as described below:

- The proposed project is the hydropower plant, which supply electricity to EPG.
- The Project will be newly installed at a site where there was no renewable energy power plant operating prior to the implementation of the project activity.
- The project activity results in new reservoirs and the power density of the power plant will be 15.46 W/m², which is greater than 10W/m².
- The installed capacity of the Project is 7.5 MW, which is smaller than 15 MW.
- The proposed plant is not combined heat and power system.

All the structures and equipment such as a dam, turbines and generators will be designed and constructed so as to comply with capacity of 10 MW. It is, therefore, impossible to increase their capacity up to 10 MW during the operation of the plant. So, the proposed project will not exceed 15 MW during the crediting period.

Therefore, the proposed plant is eligible to apply the methodology AMS-I.D

B.3. Description of the project boundary:

>>

As for the guidelines mentioned in paragraph 4 of Type I.D. described in Appendix B of the simplified modalities & procedures for small-scale CDM-project activities, the project boundary encompasses the

CDM – Executive Board

physical and geographical site of dam, powerhouse and hydraulic turbine generators. The electricity displaced by the project activity would be the electricity generated by the EPG.

Therefore, the spatial scope of the project boundary covers the project site and all power plants connected physically into EPG. Geographically, the EPG is composed of Ryanggang Province, North Hamgyong Province, South Hamgyong Province and Kangwon Province.

Table.3 Emission sources and gases included in the project boundary for the purpose of calculating project emissions and baseline emissions.

Source		Gas	Included/Excluded	Justification/ Explanation
Baseline	Electricity production in the EPG	CO ₂	Included	Main emission sources.
		CH ₄	Excluded	Excluded for simplification. This is conservative.
		N ₂ O	Excluded	Excluded for simplification. This is conservative.
Project Activity	Kumya Hydropower Plant	CO ₂	Excluded	The project does not lead to CO ₂ emission.
		CH ₄	Excluded	The project does not lead to CO ₂ emission.
		N ₂ O	Excluded	The project does not lead to CO ₂ emission.

B.4. Description of baseline and its development:

>>

The government of DPR Korea gives higher priority to the development of the electricity industry than the other sectors in the national economy according to the “Law on electric power industry” adapted on 20 November 1995 /16/.

The government stipulated that the thermal power plants should be constructed in combination with other plants relying on several generation sources while giving priority to the construction of hydropower plants and large scale plants should be constructed simultaneously with small scale plants /16, 17/.

The baseline of the project activity will be decided as per the methodology AMS-I.D (Version 17, EB 61) In accordance with AMS-I.D, if the project activity is the installation of a new grid-connected renewable power plant/unit, the baseline scenario is the electricity delivered to the grid by the project activity that otherwise would have been generated by the operation of grid-connected power plants and by the addition of new generation sources.

Following baseline scenario options have been identified as realistic and credible alternatives to the project activity:

1. The proposed project activity undertaken without being registered as a CDM project activity
2. Thermal power plant generation with annual equivalent power generation
3. Other renewable sources power generation plant with annual equivalent power generation
4. Annual equivalent electricity is supplied by EPG

 CDM – Executive Board

The baseline scenario options described above are discussed individually considering relevant laws and regulation, as well as investment analysis:

Baseline scenario option 1: the proposed project activity undertaken without being registered as a CDM project activity

The first scenario is in compliance with relevant laws and regulations of DPR Korea, but not a mandatory project. Whether this scenario is a feasible alternative or not, it can be further judged through investment analysis. According to the investment analysis on the proposed project, without CDM revenue, the IRR of the Project is 3.71%, which is lower than the benchmark 5%. Therefore, the results of the sensitivity analysis confirm that the project faces significant economic and financial barriers without CDM revenue. So, the first scenario is not feasible.

Baseline scenario option 2: thermal power generation plant with equivalent annual power generation.

The second scenario is also in compliance with relevant laws and regulations of DPR Korea (“*law of DPR Korea on medium and small scale plants*”, 11 April 2007) /17/

But this alternative is impossible with the following reasons:

- ✓ It is difficult to obtain the technical information for financial and economic estimation on small-sized fossil fuel plants, and necessary specific regulations/rules because there is no practice of construction for small fossil fuel plants in DPR Korea ;
- ✓ It is difficult for a County-level company to build infrastructure such as railway to be used to transport coal by its own efforts because the area is a rural area with lack of finance and capacity;
- ✓ There is no company that has ever built any small thermal power plant with the same capacity as the proposed project in DPR Korea and the capacities of companies in local area are insufficient to construct and operate small thermal power plants;
- ✓ It is difficult to make a contract for the design document and the generating equipment needed for construction of small thermal power plants because there is no specialized institution that has enough experiences in DPR Korea:

Therefore, alternative (2) is not feasible.

Baseline scenario option 3: other renewable sources power generation plant with annual equivalent power generation

The third scenario is also in compliance with regulations and rules of DPR Korea /17/.

But, as the second scenario, there is no wind, tidal, solar and biomass power plants of the same capacity as the proposed project in DPR Korea /20/ and the construction of these plants are still under study and experiment by specialized institutions in the relevant area. Therefore, it is difficult to estimate the financial benefit of such plants. In addition, it is estimated that the renewable energy resources other than hydro in this area is insufficient for generating electricity as much as the proposed project. Therefore, alternative (3) is not feasible.

Baseline scenario option 4: the annual equivalent electricity is supplied by EPG

The baseline scenario option is in compliance with relevant laws and regulations, and without financial barrier and other barriers.

Conclusion:

From the above analysis we can conclude that the fourth scenario is the most feasible scenario. As a result, in the absence of the project, electricity will be continued to be generated by the existing power plants in

CDM – Executive Board

EPG.

The baseline emissions are the product of electrical energy baseline $EG_{BL,y}$ expressed in MWh of electricity produced by the renewable generating units multiplied by the grid emission factor.

The emission factor can be calculated according to method 12(a) selected from the methodology AMS-I.D (Version 17, EB 61) as: CM, consisting of the combination of OM and BM according to the procedures prescribed in the tool to calculate the emission factor for an electricity system. The boundary of the proposed project is EPG, so the boundary when calculating the OM emission factor and BM emission factor are set with in EPG.

The key parameters used to determine the baseline emissions are tabled below.

Table.4 Data used to determine baseline emissions

Parameter	Source
Amount of fossil fuel consumed	Central Bureau of Statistics
Net calorific value of fuel consumed	Data of IPCC
Net electricity generated and delivered to the grid	Central Bureau of Statistics
Emission factor of fuel consumed	Data of IPCC
Date of complete construction of power plant	Kumya Hydropower Plant Operation and Construction Company

B.5. Description of how the anthropogenic emissions of GHG by sources are reduced below those that would have occurred in the absence of the registered small-scale CDM project activity:

>>

The Project is a small scale project activity. As such, the provisions of Attachment A to Appendix B of the “*simplified modalities and procedures for small-scale CDM project activities*” will apply to the Project. The “*indicative simplified baseline and monitoring methodologies for selected small-scale CDM project activity category*” require the project proponents to show that the project activity would not have occurred anyway due to *at least one* of the following barriers:

- (a) Investment barrier
- (b) Technological barrier
- (c) Barrier due to prevailing practices / common practice
- (d) Other barriers

The barriers specified in Attachment A to Appendix B are:

a) Investment barrier: A financially more viable alternative to the project activity would have led to higher emissions.

b) Technological barrier: A less technologically advanced alternative to the project activity involves lower risks due to the performance uncertainty or low market share of the new technology adopted for the project activity and so would have led to higher emissions.

c) Barrier due to prevailing practice: Prevailing practice or existing regulatory or policy requirements would have led to implementation of a technology with higher emissions.

d) Other barriers: Without the project activity, for another specific reason identified by the project participant, such as institutional barriers or limited information, managerial resources, organizational capacity, financial resources, or capacity to absorb new technologies, emissions would have been higher.

CDM – Executive Board

The main barrier existing in the project is investment barrier.

1. CDM consideration

There is no energy industry sector originally in Kumya County and the electricity used in Kumya County has been supplied from the EPG. People in Kumya County think that it is very difficult to construct the hydro power plant along the Kumya River because there is no practice in constructing the hydropower plant and that project activity is very unattractive. Project owner got to know CDM since DNA of DPR Korea had issued the letter of recommendation for CDM and the significant effort of General Bureau for Cooperation with International Organizations (GBCIO) became an incentive to the decision of CDM project activity the project owner made.

Prior to the start of the project, project owner has seriously considered the project activity as CDM.

FSR and EIA were made by Central Electric Power Design Institute (CEPDI) and Environment & Development Centre (EDC) respectively under the project owner's request. And then, FSR and EIA were estimated by CDM developing team, State Academy of Sciences (SAoS). According to the opinion of CDM developing team, Kumya Hydropower Plant was eligible for CDM project. People's Committee of Kumya County (PCKC) held a meeting to discuss the eligibility for CDM of Kumya Hydropower Plant. The result of the meeting showed that the project activity would contribute to the economical and social development and the local government agreed with the project activity and decided to receive comments from local residents as soon as possible.

The project owner decided the start of the project activity according to the result of local government's meeting and Ministry of State Construction Control (MSCC) approved the construction of hydropower plant by project owner.

After the approval by MSCC, project owner made several contract such as loan contract, construction contract, equipment contract and electricity contract with relevant entities in order to implement the project activity. The project owner submitted the application for registration as CDM project activity to the DNA

Table 5 shows the timetable of the proposed project

Table.5 Timetable of the proposed project

Date	Milestone
03/02/2009	Recommendation Letter of DNA
04/02/2010	Submission of FSR by CEPDI
05/04/2010	Approval of FSR by MSCC
11/05/2010	Submission of EIA report by EDC
10/06/2010	Approval of EIA by Bureau of land and environment protection, South Hamgyong Province
23/06/2010	Meeting of the People's Committee of Kumya County
20/07/2010	Receipt of comments from residents to be submerged
10/08/2010	Approval of forestland use
28/09/2010	PDD development contract between KHPOCC, GBCIO and SAoS
14/10/2010	Approval of plant construction by MSCC
18/10/2010	Loan contract between Kumya bank and KHPOCC
20/10/2010	Construction contract between KHPOCC and Kumyagang Hydro Power Construction Company (KHPCC)
25/11/2010	Starting date of construction
13/12/2010	Submission of prior consideration of the CDM Form to UNFCCC
10/05/2011	Equipment contract between KHPOCC and RMC

CDM – Executive Board

26/05/2011	Electricity contract between KHPOCC and Kumya Electric Power Company (KEPC)
22/08/2011	Approval of the proposed project by DNA

2. Investment barrier

Investment barrier is the main barrier the Project may face. Without the revenue from CDM, the Project would never be implemented.

The purpose of this part is to determine whether the Project is economically attractive or not through appropriate analysis method.

(1) Determination of appropriate analysis method

Though not applicable, as it is a small scale project activity, Additionality Tool (Version 06.0) stipulates that the project developer should identify the financial/ economic indicator, such as IRR, most suitable for the project type and decision context.

According to “Tool for the demonstration and assessment of additionality (Version 06.0)”, three options can be applied to conduct the investment analysis. They are: the simple cost analysis (Option I), the investment comparison analysis (Option II) and the benchmark analysis (Option III).

Since this project will generate financial/economic benefits other than CDM-related income, through the sale of generated electricity, Option I (Simple Cost Analysis) is not applicable.

The investment comparison analysis (Option II) is also not applicable for the proposed project because investment comparison analysis method is only applicable to projects whose alternatives are similar investment projects. Therefore Option II is not appropriate.

Then the benchmark analysis (Option III) will be used to identify whether the financial indicators, Financial Internal Return Rate (IRR) in this project is better than relevant benchmark value.

(2) Selection and Validation of Appropriate Benchmarks

EB 62 Report Annex 5, “Guidelines on the Assessment of Investment Analysis” (Version 05), section 12 requires,

“In cases where a benchmark approach is used the applied benchmark shall be appropriate to the type of IRR calculated. Local commercial lending rates or weighted average costs of capital (WACC) are appropriate benchmarks for a project IRR. Required/expected returns on equity are appropriate benchmarks for an equity IRR. Benchmarks supplied by relevant national authorities are also appropriate if the DOE can validate that they are applicable to the project activity and the type of IRR calculation presented.” Also section 13 requires: “In the cases of projects which could be developed by an entity other than the project participant the benchmark should be based on parameters that are standard in the market.”

According to the “Guideline for determination of main parameters of hydro power plants” (MSCC, 2006), it stipulated that the project must be not implemented, in cases where the IRR of hydropower project is less than 5%. Therefore, the threshold can be used as benchmark.

This benchmark fits to the conditions above.

- This benchmark is used in the construction of hydropower plants in DPR Korea.
- This benchmark is publicly available data source and can be clearly validated by the DOE.
- This benchmark is used in deciding the implementation of hydropower project among the project

CDM – Executive Board

owners.

3. Calculation and comparison

Based on the Feasibility Study Report of the Project, the basic parameters for calculation of financial indicators are shown in table 6.

Table.6 Basic parameters for calculation of financial indicators of the Project

Parameters	Value	Source
Installed capacity(MW)	7.5	FSR, page 8
Net electricity supplied to EPG (GWh)	22.5	FSR, page 9
Total investment(10,000KPW)	54,284	FSR, page 43
Annual loan rate (%)	3.6	Guideline for determination of main parameters of hydro power plants /3/
The price of electricity to be sold to EPG (KPW/kWh)	1.98	Guideline for determination of main parameters of hydro power plants /3/
Annual O&M cost(10,000KPW)	674.5	FSR, Page 43
Rate of depreciation of equipment (%)	5	Guideline for determination of main parameters of hydro power plants /3/
Rate of depreciation of structure (%)	2	Guideline for determination of main parameters of hydro power plants /3/
Government payment (%)	30	Guideline for determination of main parameters of hydro power plants /3/
Annual operation time (hour)	3,080	FSR, page 10
PLF (%)	35.1	calculated
Construction period(year)	2	FSR, page 43
Project lifetime	20	FSR, page 43

Base on the data given in table 6, calculating the total investment on the IRR without sale revenue of CER, IRR is lower than the benchmark 5% as it is 3.71%. Therefore, the Project is unattractive and requires the additionality.

With the sale revenue of CER, the IRR of Project on the total investment is 8.06 and exceeds the benchmark 5%. In this case, the Project is attractive, which means, as a result, that the revenue of CDM is able to help the Project to overcome the investment barrier.

Sensitivity analysis

This step is to confirm that whether the conclusion regarding to the financial attractiveness is robust to reasonable variations in the critical assumptions.

EB 62 Report Annex 5, “Guidelines on the Assessment of Investment Analysis” (Version 05), section 20 requires:

“Only variables, including the initial investment cost, that constitute more than 20% of either total project costs or total project revenues should be subjected to reasonable variation (all parameters varied need not necessarily be subjected to both negative and positive variations of the same magnitude), and the results of this variation should be presented in the PDD and be reproducible in the associated spreadsheets.”

The following four parameters are selected as the critical sensitivity indicators to check the financial attractiveness of the Project:

- Annual O&M cost ;
- Electricity supplied to the grid(feed-in electricity) ;

CDM – Executive Board

- Total investment ; and
- Electricity price.

Variations of $\pm 10\%$ (according to FSR) have been considered in the critical assumptions. Table 7 summarizes the results of the sensitivity analysis, while figure 3 provides a graphic depiction.

Table.7 Result of sensitivity analysis

Item	-10%	-5%	0	+5%	+10%	IRR equal to 5%
Fixed assets investment	4.34%	4.01%	3.71%	3.44%	3.20%	-18.50%
Annual O&M cost	3.81%	3.76%	3.71%	3.66%	3.61%	-
Feed-in electricity	3.04%	3.38%	3.71%	4.05%	4.38%	19.30%
Electricity price	3.04%	3.38%	3.71%	4.05%	4.38%	19.30%

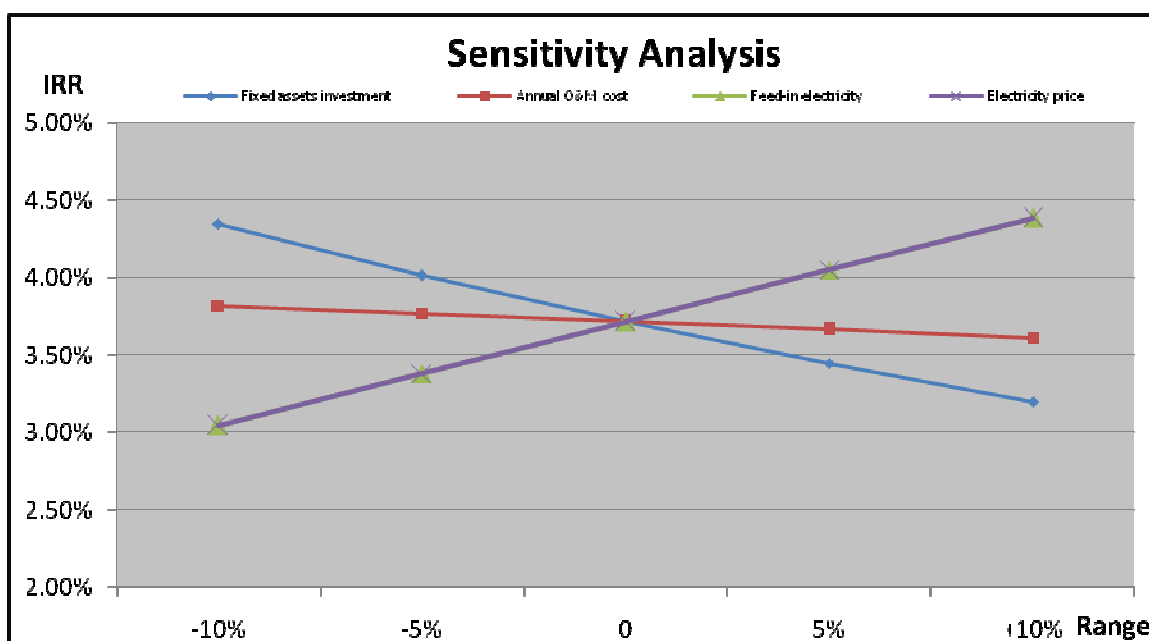

Fig.3 The IRR Sensitivity Analysis with the changes of Total Investment, Annual O&M Cost, Electricity price or Feed-in Electricity

As shown in table 7 and figure 3, with four Variations of $\pm 10\%$ having been considered, the conclusion is that with reasonable changes in the critical assumptions, the IRR will remain lower than the benchmark of 5%. Therefore, the conclusion that the Project is additional is robust.

- **Total investment**

In general, when the total investment increases, the project IRR decreases.

If the total investment increases from -10% to 10%, the project IRR would decrease from 4.34% to 3.20%.

CDM – Executive Board

As a result, although the total investment changes in the range of $\pm 10\%$, the project IRR would not reach the benchmark 5%. If the total investment decreases by 18.50%, the project IRR can reach the benchmark 5%.

But the IRR of the Project will not reach the benchmark because:

- ✓ The FSR of the proposed project was made by specialized institution, which has rich experiences in making a budget for hydropower plant construction. The institution made a budget for the proposed project based on the national standard.
- ✓ The price of main materials such as cement and steel, which are domestic goods, will not change during the construction because the price is fixed by government.

This shows that it is difficult to improve the Project IRR by reducing the total investment.

- **Feed-in Electricity**

When the electricity supplied to the grid increases, the project IRR also increases.

If the electricity supplied to the grid changes by 10%, the project IRR would change from 3.04% to 4.38%. This is smaller than the 5% of benchmark. If the electricity supplied to the grid decreases by 19.3%, the project IRR can reach the benchmark. The electricity output estimated in the FSR is the expected value based on the meteorological data for the past 30 years in the designated region.

Hydro-meteorological data in the project area is the value reported from the Bureau of Hydro-Meteorology. Bureau of Hydro-Meteorology has served hydro-meteorological data needed in construction of plants during the last years. Thus the electricity output estimated by this Bureau will not be changed so much. From this point, it is clearly impossible to improve the IRR by controlling the electricity supplied to the grid

- **Electricity price**

When the electricity price increases, the project IRR increases. If the electricity price increases by 19.5%, the project IRR will reach the benchmark.

KHPOCC and KEPC stipulated the electricity price as 1.98 KPW/kWh during the operation period in their contract. According to this contract, the electricity price will not change during the operation period

As a result, there will not be such case that the project IRR improve with increase of electricity price.

This shows that it is impossible to improve the project IRR by increasing the electricity price.

- **Operation cost**

When the operation cost decreases, the project IRR increases.

With a decrease in the annual operation & maintenance cost by 10%, the IRR has very little change. But, once the plant put in to operation, the operation cost will not change significantly. Therefore, the project IRR can not increase by adjusting the annual operation cost.

The results of sensitivity analysis confirm that the Project faces financial barriers without CDM revenue.

Conclusion

We therefore conclude that without CDM, the project faces several barriers, which would prevent the construction and implementation of the specific project activity. CDM helps to overcome these barriers.

If the Project is not implemented, electric power will be supplied by the EPG, which partly depends on thermal power as its energy source. Thermal power has GHG emissions associated with it.

CDM – Executive Board

The specific project activity will not be implemented without the registration as a CDM project and will not reduce GHG emissions below the baseline. Therefore, the specific project activity is additional.

B.6. Emission reductions:

>>

B.6.1. Explanation of methodological choices:

>>

In order to calculate the baseline, project and leakage emissions and hence emission reductions, methodology AMS-I.D (Version 17, EB 61) is used in conjunction with the “*Tool to calculate the emission factor for an electricity system* (Version 02.2.1)”. Below is a description of how the three types of emission (baseline, project and leakage) are calculated, along with the key assumptions and rationale for methodological choices.

Baseline emissions

The baseline emissions are the product of electrical energy baseline $EG_{BL,y}$ expressed in MWh of electricity produced by the renewable generating unit multiplied by the grid emission factor.

$$BE_y = EG_{BL,y} \times EF_{grid,CM,y} \quad (1)$$

Where:

BE_y Baseline emissions in year y (tCO₂)

$EG_{BL,y}$ Quantity of net electricity supplied to the grid as a result of implementation of the CDM project activity in year y (MWh)

$EF_{grid,CM,y}$ Emission factor of the grid in year y (tCO₂/MWh)

The emission factor can be calculated in a transparent and conservative manner as follows:

- (a) CM, consisting of the combination of OM and BM according to the procedures prescribed in the “*Tool to calculate the emission factor for an electricity system*”.

OR

- (b) The weighted average emissions (in tCO₂/MWh) of the current generation mix. The data of the year in which project generation occurs must be used.

Calculations shall be based on data from an official source (where available) and made publicly available.

Method (a) has been selected for baseline calculations of the proposed project because the data of the year in which project generation occurs is very difficult to acquire. Therefore the emission factor has been calculated using the procedures in the “*Tool to calculate the emission factor for an electricity system*”.

According to “*Tool to calculate the emission factor for an electricity system* (Version 02.2.1)”, project participants shall apply the following six steps to calculate the emission factor.

STEP.1 Identify the relevant electricity systems

STEP.2 Choose whether to include off-grid power plants in the project electricity system (optional)

STEP.3 Select a method to determine OM

STEP.4 Calculate OM emission factor according to the selected method

STEP.5 Calculate BM emission factor

STEP.6 Calculate CM emissions factor

Step 1: Identify the relevant electricity systems

For determining the electricity emission factors, a project electricity system and a connected electricity system should be defined.

If the DNA of the host country has published a delineation of the project electricity system and the connected electricity systems, these delineations should be used.

Because the DNA of DPR Korea has published a delineation of the project electricity system and connected electricity systems, the electricity generated by the Project will be transmitted to the EPG. As for EPG, there is none of electricity transferring from connected electricity system to the project electricity system, so it is not referred to electricity imports.

Step 2: Choose whether to include off-grid power plants in the project electricity system (optional)

Project participants may choose between the following two options to calculate OM and BM emission factor:

Option I: Only grid power plants are included in the calculation.

Option II: Both grid power plants and off-grid power plants are included in the calculation.

For the proposed project, option I was chosen because the off-grid power plant/unit which complies with conditions in the “tool to calculate the emission factor for an electricity system” (Version 02.2.1) doesn’t exist in the EPG.

Step 3: Select a method to determine OM

According to “tool to calculate the emission factor for an electricity system” (Version 02.2.1), four alternatives could be used to calculate the OM:

- (a) Simple OM; or
- (b) Simple adjusted OM; or
- (c) Dispatch data analysis OM; or
- (d) Average OM.

According to this “Methodological Tool”, the simplified CM method can only be used if:

- The project activity is located in a Least Developed Country(LDC) or in a country with less than 10 registered projects at the starting date of validation; and
- The data requirements for the application of step 5 cannot be met.

Under the simplified CM, OM emission factor must be calculated using the average OM.

For the proposed project, simplified CM method can be applied because the Project is located in DPR Korea with less than 10 registered projects and the data requirements for the application of step 5 cannot be met.

So, to determine OM emission factor, average OM (d) was chosen.

For the average OM, emission factor can be calculated using either ex-ante option or ex post option.

- *Ex ante* option: if the *ex ante* option is chosen, the emission factor is determined once at the validation stage, thus no monitoring and recalculation of the emissions factor during the crediting period is required. For grid power plants, a 3-year generation-weighted average should be used, based on the most recent data available at the time of submission of the CDM-PDD to the DOE

for validation. For off-grid power plants, a single calendar year within the 5 most recent calendar years prior to the time of submission of the CDM-PDD for validation should be used.

- *Ex post* option: if the *ex post* option is chosen, the emission factor is determined for the year in which the project activity displaces grid electricity, requiring the emission factor to be updated annually during monitoring. If the data required to calculate the emission factor for year y is usually only available later than six months after the end of year y , alternatively the emission factor of the previous year $y-1$ may be used. If the data is usually only available 18 months after the end of year y , the emission factor of the year preceding the previous year $y-2$ may be used. The same data vintage (y , $y-1$ or $y-2$) should be used throughout all crediting period.

Ex ante option was employed for OM calculation of the proposed project, without requirement to monitor and recalculate the emissions factor during the crediting period.

Step 4: Calculate OM emission factor according to the selected method

The average OM emission factor is calculated as the average emission rate of all power plants serving the grid, using the methodological guidance of the simple OM, but including in all equations also low-cost/must-run power plants.

The average OM may be calculated:

Option A: based on the net electricity generation and a CO₂ emission factor of each power unit, or

Option B: based on the total net electricity generation of all power plants serving the system and the fuel types and total fuel consumption of the project electricity system.

Option B can only be used if:

- (a) The necessary data for Option A is not available; and
- (b) Only nuclear and renewable power generation are considered as low-cost/must-run power sources and the quantity of electricity supplied to the grid by these sources is known; and
- (c) Off-grid power plants are not included in the calculation (i.e., if Option I has been chosen in Step 2).

To calculate OM of the proposed grid, Option B is applied because:

- The net electricity generation and a CO₂ emission factor of each power unit serving in the proposed grid is not available, and
- The renewable power generation is considered as low-cost/must-run power sources in DPR Korea, and
- Off-grid power plants are not included in the calculation

Under Option B, the average OM emission factor is calculated based on the net electricity supplied to the grid by all power plants serving the system, including low-cost/must-run power plants/units, and based on the fuel type(s) and total fuel consumption of the project electricity system, as follows:

$$EF_{grid,OM-ave,y} = \frac{\sum_i FC_{i,y} \times NCV_{i,y} \times EF_{CO2,i,y}}{EG_y} \quad (2)$$

Where:

$EF_{grid,OM-ave,y}$ = Average OM emission factor in year y (tCO₂/MWh)

$FC_{i,y}$ = Amount of fossil fuel type i consumed in the project electricity system in

	year y (mass or volume unit)
$NCV_{i,y}$	= Net calorific value (energy content) of fossil fuel type i in year y (GJ/mass or volume unit)
$EF_{CO_2,i,y}$	= CO ₂ emission factor of fossil fuel type i in year y (tCO ₂ /GJ)
EG_y	= Net electricity generated and delivered to the grid by all power sources serving the system, including low-cost/must-run power plants/units, in year y (MWh)
i	= All fossil fuel types combusted in power sources in the project electricity system in year y
y	= The relevant year as per the data vintage chosen in Step 3

Based on most recent 3years data of the annex 3(2007-2009), the average OM emission factor is 0.8833 tCO₂/MWh.

Step 5: Calculate BM emission factor

Plants in EPG have units that are different in the launched date, generation output and consumption of fuel. The information of each power unit in EPG is very difficult to acquire in DPR Korea. So, the sample group of power units used to calculate BM could not be determined as per the procedure in the methodology. Thus, BM emission factor is zero.

Step 6: Calculate CM emissions factor

The calculation of CM emission factor ($EF_{grid, CM, y}$) is based on one of the following methods:

- Weighted average CM: or
- Simplified CM

The weighted average CM method (option A) should be used as the preferred option.

The simplified CM method (option b) can only be used if:

- The project activity is located in a Least Developed Country (LDC) or in a county with less than 10 registered projects at the starting date of validation; and
- The data requirements for the application of step 5 above cannot be met.

For the Project, the simplified CM method (option A) was selected due to:

- The project activity is located in DPR Korea with less than 10 registered projects at the starting date of validation; and
- The data requirements for the application of step 5 above cannot be met.

The CM is calculated using equation (3) below with the following conditions:

- $w_{BM}=0$;
- $w_{OM}=1$;

CM emissions factor is calculated as follows:

$$EF_{grid, CM, y} = EF_{grid, OM, y} \times w_{OM} + EF_{grid, BM, y} \times w_{BM} \quad (3)$$

Where:

$$EF_{grid, BM, y} = \text{BM emission factor in year } y \text{ (tCO}_2\text{/MWh)}$$

CDM – Executive Board

$EF_{grid,OM,y}$ = OM emission factor in year y (tCO₂/MWh)

w_{OM} = Weighting of OM emissions factor (%)

w_{BM} = Weighting of BM emissions factor (%)

From the formula (3), $EF_{grid,CM,y} = 0.8833 \text{ tCO}_2/\text{MWh}$

From the formula (1), $BE_y = 22,500 \times 0.8833 = 19,874 \text{ tCO}_2$

Project emissions

According to the ACM0002 (Version 12.3.0, EB 66), if the power density of the project activity (PD) is greater than 10 W/m², project emissions from water reservoir is zero.

The power density (PD) is calculated as follows:

$$PD = \frac{Cap_{PJ} - Cap_{BL}}{A_{PJ} - A_{BL}} \quad (4)$$

Where:

PD = PD of the project activity (W/m²)

Cap_{PJ} = Installed capacity of the hydro power plant after the implementation of the project activity (W)

Cap_{BL} = Installed capacity of the hydro power plant before the implementation of the project activity (W). For new hydro power plants, this value is zero

A_{PJ} = Area of the reservoir measured in the surface of the water, after the implementation of the project activity, when the reservoir is full (m²)

A_{BL} = Area of the reservoir measured in the surface of the water, before the implementation of the project activity, when the reservoir is full (m²). For new reservoirs, this value is zero

PD of the proposed project is calculated as follows:

$$PD = Cap_{PJ} / A_{PJ} = 7.5 / 0.485 = 15.46 \text{ W/m}^2 \quad (5)$$

According to this methodology, Project emissions from water reservoirs ($PE_{HP,y}$) is zero

Leakage emissions

If the energy generating equipment is transferred from another activity, leakage is to be considered.

For the proposed project, leakage is zero, because there is no transfer of energy generating equipment.

$$LE_y = 0 \quad (6)$$

Emission reductions

Emission reductions are calculated as follows:

$$ER_y = BE_y - PE_y - LE_y \quad (7)$$

Where:

ER_y = Emission reductions in year y (tCO₂e/y)

BE_y = Baseline emissions in year y (tCO₂/y)

PE_y = Project emissions in year y (tCO₂e/y)

LE_y = Leakage emissions in year y (tCO₂e/y)

For the proposed project, emission reductions are as follows;

CDM – Executive Board

$$ER_y = BE_y = EG_y \times EF_{grid,CM,y} = 19,874 \text{ tCO}_2e \quad (8)$$

B.6.2. Data and parameters that are available at validation:

Data / Parameter:	$NCV_{i,y}$
Data unit:	TJ/Gg
Description:	Net calorific value (energy content) per mass or volume unit of a fuel <i>i</i>
Source of data used:	Volume 2 of 2006 IPCC Guidelines for National Greenhouse Gas Inventories
Value applied:	Refer to Annex 3
Justification of the choice of data or description of measurement methods and procedures actually applied :	IPCC default values are world-widely used.
Any comment:	IPCC data

Data / Parameter:	$FC_{i,y}$
Data unit:	Gg
Description:	The amount of fuel <i>i</i> consumed in EPG in year <i>y</i>
Source of data used:	Central Bureau of Statistics
Value applied:	Refer to Annex 3
Justification of the choice of data or description of measurement methods and procedures actually applied :	The data from Central Bureau of Statistics is official statistics and publicly accessible and reliable data source.
Any comment:	Official data

Data / Parameter:	EG_y
Data unit:	MWh
Description:	Net electricity generation produced and delivered by all units connected in EPG in year <i>y</i>
Source of data used:	Central Bureau of Statistics
Value applied:	Refer to Annex 3
Justification of the choice of data or description of measurement methods and procedures actually applied :	The data from Central Bureau of Statistics is official statistics and publicly accessible and reliable data source.
Any comment:	Official data

Data / Parameter:	$EF_{CO_2,i}$
Data unit:	tCO₂/TJ
Description:	The emission factor of fuel <i>i</i> in a mass or volume unit

CDM – Executive Board

Source of data used:	Volume 2 of 2006 IPCC Guidelines for National Greenhouse Gas Inventories
Value applied:	Refer to Annex 3
Justification of the choice of data or description of measurement methods and procedures actually applied :	IPCC default values are world-widely used.
Any comment:	IPCC data

B.6.3 Ex-ante calculation of emission reductions:

>>

The baseline emission factor is shown in the table 8

Table.8 Calculation of CM in EPG (tCO₂e/MWh)

OM	BM	CM
0.8833	0	0.8833

Because the electricity supplied from the Project to the EPG is 22.5GWh, the project emission reductions are calculated as follows:

Baseline emissions

$$BE_y = EG_y \times EF_{grid, CM, y} = 22,500 \times 0.8833 = 19,874 \text{ tCO}_2e \quad (9)$$

Leakage

As mentioned in the B6.1

$$LE_y = 0$$

Project emissions

$$PE_{HP, y} = 0 \text{ tCO}_2e$$

Emission reductions

Since leakage and project emissions from the Project are zero, CER estimated by the Project in a year can find from following:

$$ER_y = BE_y = EG_y \times EF_{grid, CM, y} = 22,500 \times 0.8833 = 19,874 \text{ tCO}_2e \quad (10)$$

B.6.4 Summary of the ex-ante estimation of emission reductions:

>>

Table9 shows the emission reductions of the Project during the first crediting period.

Table.9 Estimate of emission reductions of the project during the first crediting period

Year	Estimation of project activity emissions (tCO ₂ e)	Estimation of baseline emissions (tCO ₂ e)	Estimation of leakage (tCO ₂ e)	Estimation of overall emission reductions (tCO ₂ e)
01/01/2013-31/12/2013	0	19,874	0	19,874
01/01/2014-31/12/2014	0	19,874	0	19,874

CDM – Executive Board

01/01/2015-31/12/2015	0	19,874	0	19,874
01/01/2016-31/12/2016	0	19,874	0	19,874
01/01/2017-31/12/2017	0	19,874	0	19,874
01/01/2018-31/12/2018	0	19,874	0	19,874
01/01/2019-31/12/2019	0	19,874	0	19,874
01/01/2020-31/12/2020	0	19,874	0	19,874
01/01/2021-31/12/2021	0	19,874	0	19,874
01/01/2022-31/12/2022	0	19,874	0	19,874
Total emission reductions (tCO₂e)	0	198,740	0	198,740
Credible period (year)	10			
Annual average during the credible period (tCO₂e)	19,874			

B.7 Application of a monitoring methodology and description of the monitoring plan:
B.7.1 Data and parameters monitored:

Data / Parameter:	<i>EG_{facility,v}</i>
Data unit:	MWh
Description:	The net electricity delivered by the Project
Source of data to be used:	FSR
Value of data	22,500
Description of measurement methods and procedures to be applied:	Measured continuously, recorded daily and archived on a monthly basis
QA/QC procedures to be applied:	According to national standard, meters will be calibrated once a year. Data measured by meters will be cross checked by electricity sales receipt.
Any comment:	Refer to B.7.2. Description of the monitoring plan

Data / Parameter:	<i>Cap_{PJ}</i>
Data unit:	MW
Description:	Installed capacity of the hydro power plant after the implementation of the project activity
Source of data to be used:	FSR
Value of data	7.5
Description of measurement methods and procedures to be applied:	The capacity of the Project will be recorded according to the installed units once a year.
QA/QC procedures to be applied:	The installed capacity will not be changed during the crediting period and will not affect the calculation of emission reductions by the Project

CDM – Executive Board

Any comment:	Refer to B.7.2. Description of the monitoring plan
Data / Parameter:	A_{PJ}
Data unit:	km^2
Description:	Area of the reservoir measured in the surface of the water, after the implementation of the project activity, when the reservoir is full
Source of data to be used:	FSR
Value of data	0.485
Description of measurement methods and procedures to be applied:	The area will be monitored at the end of each year by topographical surveys and maps
QA/QC procedures to be applied:	The power density of the Project is 15.46 W/m^2 . Although area of the reservoir changes during the operation period, the power density of the Project will be above 10 W/m^2 .
Any comment:	

B.7.2 Description of the monitoring plan:
--

>>

This monitoring plan is applied to the Project that is developing according to the “*Simplified Modalities and Procedures for Small-scale CDM Project Activities*” and “*Enforcement regulation on metering method of DPR Korea*” (Dec 2009) in South Hamgyong Province.

The objective of the monitoring plan is to insure the complete, consistent, clear, and accurate monitoring and calculation of the emissions reductions during the whole crediting period.

1. Data to be monitored

In this PDD, emission factor of the Project is determined ex-ante. Therefore the net electricity generation supplied to the grid by the Project is defined as the key data to be monitored. The monitoring plan is drafted to focus in monitoring of this data.

2. Monitoring Organization

The project owner will organize the monitoring team to take charge of monitoring the data and information relating to the calculation of emission reductions and assign the responsibility to all officers.

The team leader will be appointed by the project owner, who supervises and identifies metering and recording, data collecting and calculating of emission reductions and prepares a monitoring report.

Technical officer will be responsible for calibrating and maintaining the meters and checking, archiving and managing data.

Financial officer will be responsible for collecting financial data required by the checking activity, including meters readings record and the receipts of electricity sales.

Statistical officer will be responsible for measuring and recording the meter readings, and making a regular summary according to requirement of the team leader, who is in charge of CDM.

3. Installation of meters and metering of data

The net electricity supplied to the grid by the Project would be determined through calculating the

difference between the electricity supplied to and delivered from the grid by the Project. All those data would be continuously monitored by the electric meters located at the monitoring spot both agreed by the project owner and the grid company. Figure.4 shows location of monitoring meters to be installed in the proposed electricity system. All the meters have function of automatic measurement of electric power, back up and bidirectional measurement. The error limit of all the meters is $\pm 0.5\%$

All the meters will connect to the computer equipped with Supervision Control and Data Acquisition (SCADA) system and all the information from meters will be automatically recorded by the computer. Meanwhile, the meter 1 will indicate the electricity exported from the outdoor substation of the plant and the meter 2 will indicate the net electricity supplied to the grid.

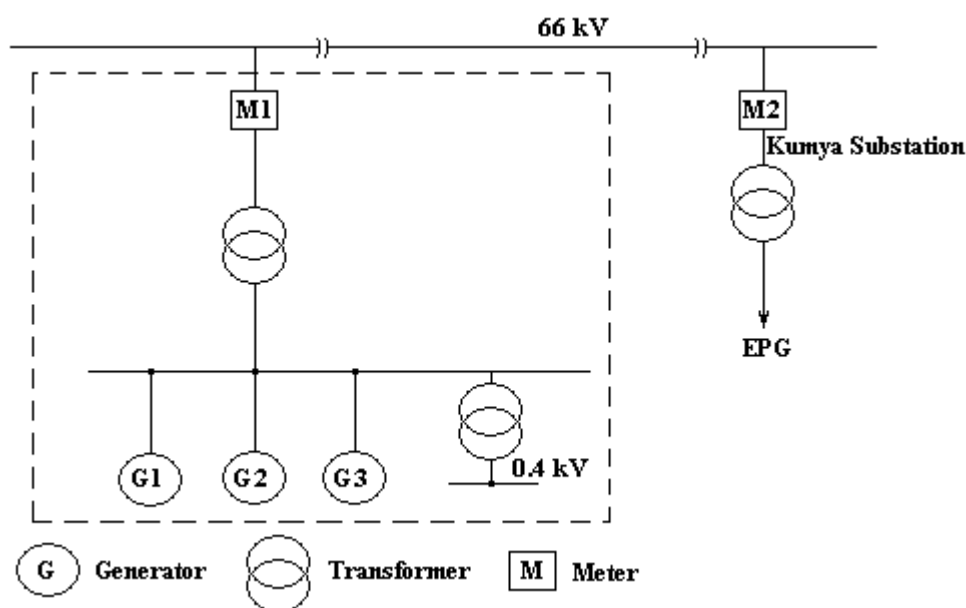

Fig.4. Monitoring system of Project

4. Calibration

Before installation at the proposed plant, meters will be checked and calibrated by Measurement Institute (MI) under the State Quality Control Committee according to the “Enforcement regulation on metering method of DPR Korea” (Dec 2009) and the “*Technical regulation on electrical equipment*” (Ministry of Electric-power Industry, 2005). Only the meters ensured by MI will be installed at the spot. According to the regulation, the error limit should be $\pm 0.5\%$. Project owner and Grid Company will install and seal the meters ensured by MI at the spot jointly.

During the operation period, all the meters installed at the spot will be calibrated once a year according to the national standard. Calibration will be carried out by a qualified institution. After calibration, the meters should be sealed by Operation Company, Grid Company and Qualified Institution jointly. When it needs to unseal, it requires the presence of above mentioned three institutions. One party must not unseal or control the meters without the presence of the other party.

All the meters should be reinstalled jointly by three institutions

- (a) Detection of a difference larger than the allowable error in the readings of both meters;

- (b) The repair of all meters or its parts caused by the failure of one or more parts, which are operated in accordance with the specifications.

5. Data collection

The project owner will be responsible for the operation and monitoring of the meter 1, the Grid Company and the project owner will be responsible for the operation and monitoring of the meter 2 together, and ensure that all meters are undamaged, sealed up. The monitoring staff should be responsible for reading meters everyday, and preannounce the quantity of electricity to the Grid Company in order to solve problems in time.

When the error of the meter 1 is within the allowable range, the meter 2 will be able to provide electricity receipt and verification of emission reductions. In this situation, the steps of monitoring net electricity supplied to the Grid are shown as follows:

- ✓ On the fixed day of each month, the project owner and the Grid Company will take their respective meter's reading and record these figures and the project owner will cross-check the figures from meter 1 and meter 2.
- ✓ The Grid Company provides the project owner with the actual amount of electricity that the Project supplied to the grid and the actual amount of electricity that the grid delivered to the Project
- ✓ The project owner provides the Grid Company with receipt, and keeps copy of the receipt
- ✓ The Grid Company provides the project owner with receipt of the electricity supplied to the Project, the project owner keeps the receipt
- ✓ The project owner records the net electricity supplied by the Project to grid
- ✓ The project owner provides the DOE with the record of the meter 1's recording, the record of the meter 2's recording, copy of receipt of the electricity supplied to the grid, and receipt of the electricity supplied to the Project

When the error of the meter 2 exceeds the allowable range, or can't work normally, the net electricity supplied to the Grid should be calculated as follows:

- ✓ The data from meter 1 will be used, with a minor adjustment to allow for historical potential loss rate, unless the meter 1 exceed the allowable range
- ✓ In the event of meter 1 failing, the project owner and Grid Company should design a reasonable, appropriate and conservative monitoring method together, and provide sufficient evidence to demonstrate that the method is reasonable during DOE's verification
- ✓ If the project owner and Grid Company can't reach an agreement, the problem should be settled by the relevant arbitration.

6. Data management

A monitoring officer will read the electricity generated and supplied at the fixed time everyday and record it in the paper documents. All monitoring data and records will be archived in electronic and paper documents at the end of each month. The electronic documents will be back up in CD-ROM and hard disk. The project owner will also keep copies of receipts and prepare a monitoring report when necessary, which includes the monitored parameters, the calibration record, the emission reductions calculation and meters' corrective action records.

7. Quality Assurance and Quality Control

CDM – Executive Board

All the monitoring data is forwarded to the monitoring team leader monthly, the team leader is responsible for reviewing the monitoring data and cross-checking with electricity receipt.

8. Training on Monitoring officers

The project owner will entrust the professional engineers and experts to train all the relative staffs before operation of generators. The training contains CDM knowledge, operational regulations, quality control (QC) standard, data monitoring requirements etc.

9. Monitoring Report

The project owner will keep receipt for the power delivered to the grid as a crosscheck. At the end of each crediting year, a monitoring report will be compiled detailing the metering results and evidence (i.e. receipt). The monitoring report should include: the monitoring of the electricity supplied to the grid, emission reductions calculation report, repair records and calibration records of the monitoring equipment.

B.8 Date of completion of the application of the baseline and monitoring methodology and the name of the responsible person(s)/entity(ies)

>>

Date of completion: 01/08/2011

1. Mr. Chol Ho Ham, Institute of Thermal Engineering, SAoS

Address: Moranbong district, Pyongyang, DPR Korea

E-mail Add: pptayang@star-co.net.kp,

Tel: 850-2-3818111/ext-8544

FAX: 850-2-3814410/2100

2. Mr. Song Il Kang, Institute of Thermal Engineering, SAoS

Address: Moranbong district, Pyongyang, DPR Korea

E-mail Add: pptayang@star-co.net.kp,

Tel: 850-2-3818111/ext-8544

FAX: 850-2-3814410/2100

(Not a Project Participant)

SECTION C. Duration of the project activity / crediting period

>>

C.1 Duration of the project activity:

>>

C.1.1. Starting date of the project activity:

>>

20/10/2010 (Construction Contract was signed.)

C.1.2. Expected operational lifetime of the project activity:

>>

The expected operational lifetime of the project activity is 20 years, including the construction periods.

C.2 Choice of the crediting period and related information:

CDM – Executive Board

>>

C.2.1. Renewable crediting period

>>

C.2.1.1. Starting date of the first crediting period:

>>

Not applicable

C.2.1.2. Length of the first crediting period:

>>

Not applicable

C.2.2. Fixed crediting period:

>>

C.2.2.1. Starting date:

>>

01/01/2013(or earliest date after registration)

C.2.2.2. Length:

>>

10 years

SECTION D. Environmental impacts

>>

D.1. If required by the host Party, documentation on the analysis of the environmental impacts of the project activity:

>>

According to the Law on Environmental Impact Assessment, EDC carried out EIA for the proposed project and EIA report was approved by Department of land and environment protection, People's Committee of Kumya County and Bureau of land and environment protection, South Hamgyong Province.

The EIA report describes the impacts on air quality, water quality, eco-environment, solid waste, noise and land use

Air quality

During the construction of the plant, it emits the exhaust gas due to the operation of building machinery and transport vehicles and produces some pollutants including the suspended dust resulting from digging or filling up with soil, and excavating a great volume of soil, etc. But if it takes the relevant measures, there will be little impact of the pollutants.

During the operation period, it will not produce pollutants which may affect the air quality. Therefore, the proposed project will not affect the air quality.

Water quality

During the construction period, it discharges wastewater due to the construction work and the concrete mixing and some domestic sewage caused by employees who are involved in the engineering work in

CDM – Executive Board

their living district. This wastewater will be treated by taking an efficient management step before discharging into the river.

During the operation period, water pollution will not be occurred. Hence, the Project will not affect the water quality.

Eco-environment

During the construction period, the damage of vegetation may be caused in a certain regions around the project area. But the damaged vegetation regions will be recovered to its original state by undertaking the relevant tree-planting according to the process of the project construction.

And it may cause a certain impact on aquatic ecosystem due to the project construction, but it rather provides a favorable condition and environment for the living and breeding of fish by forming a reservoir.

Around the project area there is no rare or endangered species of animal which should be protected by the state, and most of them migrate to the adjacent area. Therefore, there is no great impact on terrestrial ecosystem.

As a result, the Project will not give negative impact on eco-environment.

Solid waste

The major solid waste due to the proposed project is the engineering wastes resulting from the construction site and domestic garbage caused by the employees who are involved in the engineering work.

These construction wastes will be recycled if possible, and the residue will be land-filled so as to avoid the impact on the surrounding environment. And it will plant trees on those lands, thus it will not bring any negative impact.

Based on the component of wastes, the amount of wastes produced and its scale, characteristics of the surrounding area, it will build the burial ground of wastes in the engineering area and make the litter bins in the living area so that the domestic garbage would be carried and disposed by trucks.

Therefore there will be no great impact of the solid waste on the environment due to the Project.

Noise

The main noise source of the proposed project that may affect the environment is the intermittent noise source that occurs during the construction period and little great impact is occurred when the relevant preventive measures are taken.

Land use

Some lands and residential area will be submerged by the project construction. There is no farmland in the area to be submerged and it is mainly composed of shrub.

The project owner will be responsible for the resettlement of the flooded residents. They will be moved to the surrounding area after building new dwelling houses and buildings by the project owner. After the completion of the Project, the used land will be recovered into its integrity.

D.2. If environmental impacts are considered significant by the project participants or the host Party, please provide conclusions and all references to support documentation of an environmental impact assessment undertaken in accordance with the procedures as required by the host Party:

>>

The Bureau of Land and Environment Protection, South Hamgyong Province estimated that the positive

CDM – Executive Board

impacts of the Project are more significant than negative impact in social and environmental aspects.

SECTION E. Stakeholders' comments

>>

E.1. Brief description how comments by local stakeholders have been invited and compiled:

>>

The chairman of the PCKC announced that the plant would be built from 25 November 2010 at the meeting with all the managers of the County presented.

These participated managers informed their employees of his announcement and several officers of PCKC visited the residential district to inform the news of the plant construction. In order to give a correct understanding to the local residents, the project owner broadcasted about the project activity through the local radio. Also, the project owner allowed the stakeholders to visit the construction site and to suggest the issues related with the project activity.

The People's Committee of Kumya County was responsible to receive the comment from local stakeholders.

According to the "Law on liquidated damages" and "Law on complaint and petition" of DPR Korea, all the citizens have rights to be compensated for the damage they suffered due to the other individuals or institutions and they can make complaint or petition to be ensured their own rights and interests.

There is a department for appeals and complaints in PCKC to deal with the comments from local stakeholders. The comments are received in writing and solved once a week. Anyone could put his comment in the reception department. Comments from local stakeholders will be kept in storage during the construction. Especially, Comments from residents in the submerged area are received by questionnaires prepared for them.

PCKC distributed questionnaires to the local residents, received the comments from them on 8 June 2010. Comments from the local residents will be open until the end of the project construction.

E.2. Summary of the comments received:

>>

Most residents agreed to build the Project.

Survey result by the department for appeals and complaints in PCKC is as follows.

Table.10 Summary of respondents

Item	Content	Frequency	%
Gender	male	22	44
	female	28	56
Ages	<30	8	16
	30-40	25	50
	>40	17	34
Education	Middle school	37	74
	University	13	26
Employment	officials	6	12
	workers	11	22
	farmers	33	66

CDM – Executive Board

The comments are as follows:

- Project owner should provide new dwelling houses to the residents before the plant put into operation.
- Project owner should provide new job opportunities to the residents in the area to be submerged.
- Project owner should designate the plant site outside of the stock-farm.
- Project owner should provide a better living condition than before.
- Project owner should provide the employment opportunities to the residents in Kumya County during the construction and operation period.
- Project owner should not deteriorate the environment in this area during the construction period.
- Where should the affected residents move to?
- How many people can be employed at the construction site?

The project owner answered the questioners enough and all the questioners agreed with the project activities.

E.3. Report on how due account was taken of any comments received:

>>

The public survey shows that the local residents are all positive to the Project. Taking into account the comments received from the questionnaires, the project owner took the following measures:

- The project owner will build new dwelling- houses for the resettled residents.
- Hydropower plant will be built apart from the stock-farm.
- New road will be built for the local residents.
- Several hundred of residents in Kumya County will be provided new job opportunities during the construction period transiently and several tens of residents will be employed permanently during the operation period
- Project owner will recover the construction site and construct the embankment around the plant.
- Project owner will prohibit lumbering for cooking and heating near mountains

CDM – Executive Board

Annex 1**CONTACT INFORMATION ON PARTICIPANTS IN THE PROJECT ACTIVITY**

Organization:	Kumya Hydropower Plant Operation and Construction Company (KHPOCC)
Street/P.O.Box:	Kumya County, South Hamgyong Province, DPR Korea
Building:	
City:	Kumya County
State/Region:	DPR Korea/ South Hamgyong Province
Postfix/ZIP:	
Country:	Democratic People's Republic of Korea
Telephone:	850-2-381-5926
FAX:	850-2-381-4654
E-Mail:	gbcio@star-co.net.kp
URL:	
Represented by:	Ri Yong Nam
Title:	Director, Carbon-trade Division
Salutation:	Mr.
Last Name:	Ri
Middle Name:	
First Name:	Yong Nam
Department:	Carbon Trade Division
Mobile:	
Direct FAX:	850-2-381-4654
Direct tel:	850-2-381-5926
Personal E-Mail:	

CDM – Executive Board

The Buyer

Organization:	Topič Energo s.r.o.
Street/P.O.Box:	Pavelčákova 437/6 779 00 Olomouc,
Building:	
City:	
State/Region:	
Postfix/ZIP:	
Country:	Czech Republic
Telephone:	+420 581 299 055
FAX:	+420 581 76 21 24
E-Mail:	blazek@topic-energo.cz
URL:	http://www.topic-energo.cz
Represented by:	
Title:	Managing Director
Salutation:	Mr.
Last Name:	Blažek
Middle Name:	
First Name:	Miroslav
Department:	
Mobile:	+420 731 688 910
Direct FAX:	
Direct tel:	
Personal E-Mail:	

Annex 2

INFORMATION REGARDING PUBLIC FUNDING

There is no public funding from Annex I Parties for the Project.

Annex 3**BASELINE INFORMATION****Table.11 Information of electricity supplied to the grid and fuels consumed by thermal power plants in 2007**

Thermal Power Plant	Electricity (10 ³ MWh)	Anthracite Consumption(Gg)	Lignite Consumption(Gg)	Residual Fuel Oil Consumption(Gg)
Pukchang	9,016	6,401		71.3
Chongjin	252		393	2.0

Data source: Central bureau of statistics, 2008

Table.12 Information of electricity supplied to the grid and fuels consumed by thermal power plants in 2008

Thermal Power Plant	Electricity (10 ³ MWh)	Anthracite Consumption(Gg)	Lignite Consumption(Gg)	Residual Fuel Oil Consumption(Gg)
Pukchang	9,259	6,676		72.2
Chongjin	288		451	3.1

Data source: Central bureau of statistics, 2009

Table.13 Information of electricity supplied to the grid and fuels consumed by thermal power plants in 2009

Thermal Power Plant	Electricity (10 ³ MWh)	Anthracite Consumption(Gg)	Lignite Consumption(Gg)	Residual Fuel Oil Consumption(Gg)
Pukchang	9,724	7,060		73.9
Chongjin	302		483	3.2

Data source: Central bureau of statistics, 2010

Table.14 Electricity supplied to the grid by Hydropower plants connected to EPG (10³MWh)

Year	2007	2008	2009
Sodusu hydro power plant	1,668	1,675	1,601
Anbjyon hydropower plant	907	1,007	970
Pujon hydropower plant	1,364	1,675	1,200
Hochon hydropower plant	2,043	2,448	1,601
Tongchon hydropower plant	117	88	104

Data source: Central bureau of statistics

Table.15 Information of fuels consumed for power generation

	Emission factor(tCO ₂ /TJ)	NCV(TJ/Gg)
Anthracite	94.6	21.6
Lignite	90.9	5.5
Residual fuel oil	75.5	39.8

Data source: 2006 IPCC Guidelines for National Greenhouse Gas Inventories

Table.16 Emission Factor in the EPG

year	2007	2008	2009	Average
Emission factor	0.878	0.858	0.915	0.8833

Annex 4
MONITORING INFORMATION

REFERENCES

- /1/ Feasibility Study Report on Kumya Hydropower Plant, 4 February 2010, Central Electric Power Design Institute.
- /2/ Environmental Impact Assessment Report on Kumya Hydropower Plant, 11 May 2010, Environment & Development Centre.
- /3/ Guideline for Determination of Main Parameters of Hydro Power Plants, November 2006, Ministry of State Construction Control
- /4/ Approval letter of EIA by Bureau of land and environment protection, South Hamgyong Province, 10 June 2010
- /5/ Minutes of PCKC, 23 June 2010
- /6/ Receipt of comments from residents to be submerged, 20 July 2010
- /7/ Approval letter of forestland use, 10 August 2010
- /8/ PDD development contract between KHPOCC, GBCIO and SAoS, 28 September 2010
- /9/ Approval letter of plant construction by MSCC, 14 October 2010
- /10/ Loan contract between Kumya bank and KHPOCC, 18 October 2010
- /11/ Construction contract between KHPOCC and KHPCC, 20 October 2010
- /12/ Equipment contract between KHPOCC and RMC, 10 May 2011
- /13/ Electricity contract between KHPOCC and KEPC, 26 May 2011
- /14/ Law of DPR Korea on Environmental Impact Assessment, 5 August 2008, Law Publishing Company.
- /15/ Law of DPR Korea on Construction, 5 August 2008, Law Publishing Company.
- /16/ Law of DPR Korea on Electric Power Industry, 5 August 2008, Law Publishing Company.
- /17/ law of DPR Korea on medium and small scale plants, 11 April 2007, Law Publishing Company.
- /18/ Law of DPR Korea on Management of Energy, 25 August 2004, Law Publishing Company
- /19/ Approval of project activity by MSCC, 14 October 2010
- /20/ Notice of CBS on the “Electricity of thermal power plant and hydro power plant in DPR Korea”, 6 July 2010
- /21/ Approval of the proposed project as CDM project by DNA, 22 August 2011
- /22/ Notice of DNA on CDM activity in DPR Korea, 3 February 2009
- /23/ Approval of the proposed project by DNA, 22 August 2011